

AquaScat 2 WTM (A)

On-line turbidity meter for water treatment



Applications

- Turbidity in raw water
- Turbidity in sedimentation stage, dosing of flocculant
- Turbidity before/after membrane filtration
- Turbidity before/after disinfection
- Turbidity in drinking water before feeding into the network
- Turbidity measurement in process and waste water

Advantages

- Non-contact free-fall measurement; optics are not contaminated
- Simple verification with a solid reference (automatic with the WTM A model)
- Extremely low basic illumination
- Extremely low-maintenance
- Convenient operation via colour touchscreen display
- Display of values and/or graphics

Industries

- Drinking water treatment
- Waste water treatment
- Process water in various industries

Innovations with real benefits

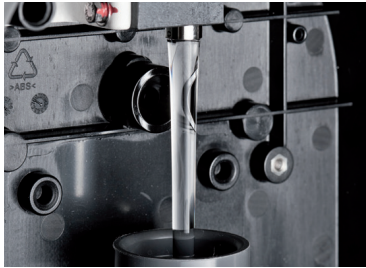

Non-contact free-fall measurement

The AquaScat models WTM and WTM A measure turbidity in a free-falling water jet. The water does not touch the optical windows.

- No contamination and therefore minimal maintenance
- High and low turbidity can be measured precisely
- The measurement of the entire sample stream leads to a representative result



Sophisticated device design

- The inherent brightening effect is extremely low. This enables precise detection of even the most minimal turbidity or the finest changes in turbidity
- An extremely stable zero point ensures reliable long-term measurements without drift
- Ideally suited for demanding process controls and for measuring turbidity in contaminated raw water



AquaScat 2 WTM Calibration with secondary turbidity standard

The AquaScat 2 WTM is calibrated with formazin at the factory. A secondary turbidity standard (solid reference) is available for recalibration during operation.

- Precise recalibration possible without toxic formazine
- The solid reference is stable and does not change its optical properties
- Low time expenditure

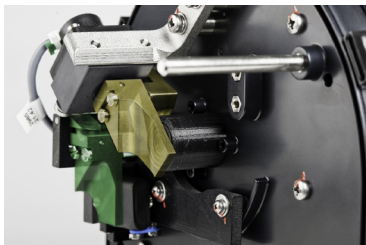

AquaScat 2 WTM A (automatic calibration)

The AquaScat 2 WTM A has an automatic calibration with a solid reference.

- Precise recalibration without toxic formazin
- The water supply does not need to be switched off for calibration
- No on-site personnel required - Ideal for measuring points that are difficult to access or unattended.



Integrated operating unit

The AquaScat WTM A has a touchscreen with colour display.

- The display shows optional values, graphics, status and alarm messages.
- An internal data memory enables the visualisation of the measurement data over the last 32 days.

Extract of technical details

Measuring principle:	90° scattered light according to ISO 7027/EN27027 standard
Light source:	LED 870 nm
Measuring range:	0 ... 4000 FNU
Accuracy*:	0 - 10 FNU: ±0.002 FNU or ±1% 10 - 4000 FNU: ±1.5%
Resolution:	0.001 FNU

* based on factory standard

Full details and technical data:



AquaScat 2 WTM (A)

Technical data

Device data

Measuring principle:	90° scattered light according to standard ISO 7027/EN27027
Light source:	LED 870 nm
Measuring range:	0 ... 4000 FNU
Accuracy*:	0 - 10 FNU: ± 0.002 FNU or $\pm 1\%$ 10 - 4000 FNU: $\pm 1.5\%$
Resolution:	0.001 FNU
Repeatability:	0.001 FNU or $\pm 0.1\%$
Sample temperature:	0 ... +40 °C
Ambient temperature:	0 ... +50 °C
Ambient humidity:	0 ... 95 % rel.
Protection (electronics):	IP66
Power supply:	18 ... 30 VDC
Power consumption max:	8 W

Installation

Sample inlet / outlet:	hose connection with internal $\varnothing 12/25$ mm
Sample flow rate:	min. 0.9 L/min, unpressurised
Material inlet / outlet:	stainless steel 1.4435 / PVC

Operating unit

Display:	1/4 VGA, 3.5"
Operation:	touchscreen
Outputs:	2 x 0/4 ... 20 mA, galvanically isolated 2 x relays 250 VAC, 4A
Inputs:	1 x for optional flow meter 2 x 0/4 ... Flow meter 2 x 0/4 ... 20 mA
Digital interfaces:	Ethernet, Modbus TCP, SD card
Optional:	- Profibus DP, Profinet IO, Modbus RTU - analogue
Optional sensors:	pH, conductivity, ORP and DO

* based on factory standard, sample flow 2.5 L/min

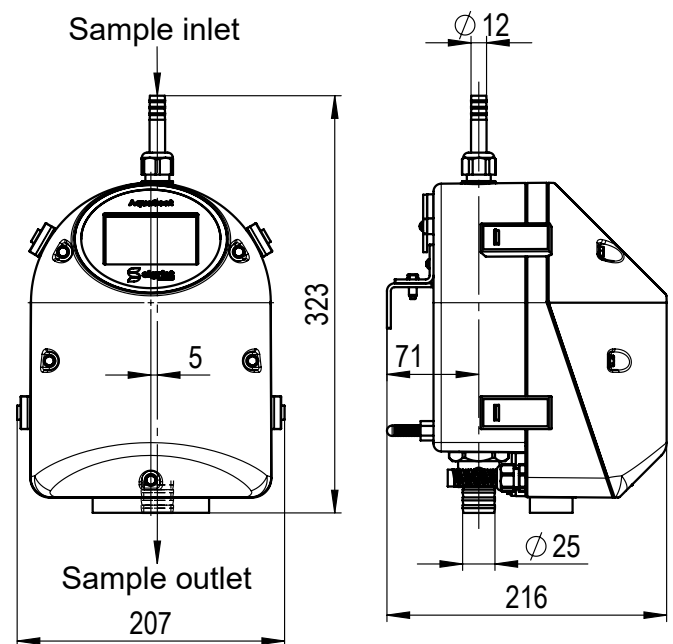

Authorised Distributor:



46, Jalan SS 22/21, Damansara Jaya,
47400 Petaling Jaya,
Selangor Darul Ehsan, Malaysia.
Email: nog@nog.com.my
Website: www.nog.com.my

