

Pressure Control Valves

Surge Relief Valves SR 6.2

Surge Relief Valve (Peak Load)



Technical Data

Connection DN	100 - 400
Nominal Pressure PN	16 - 100
Set Pressure	max. 160 bar
K _{vs} -Value	400 - 2400 m ³ /h
C _{vs} -Value	465 - 2791 US gal/min
Temperature	- 30 up to + 130 °C - 22 up to + 266 °F
Medium	liquids

Description

Surge relief valves are used for the decay of pressure surges and of permanent overpressures within pipeline systems.

SR 6.2K and SR 6.2P are self-energized valves with lowest possible response times. They operate without any auxiliary or external energy. The body is of welded design and, therefore, very lightweight compared with cast ones. Building length, connections and materials can be customised to any requirement. The straightway valve with optimised design features the least possible flow loss. The valve cone is of the soft seal type.

SR 6.2K is directly acting with piston actuation. The response pressure has been pre-set.

SR 6.2P is pilot-controlled, the response pressure and the closing time are adjustable. If a second pilot valve is used, the valve can be switched to another pre-set response pressure.

At the control unit (closing piston) the inlet pressure is in balance with the valve spring force (set value). If the inlet pressure rises above the set value, the valve opens (in the pilot valve and/or in the inner chamber of the main valve). With the inlet pressure falling the valve closes, driven by the spring tension and the increasing pressure downstream of the closing piston. In a depressurized line the valve remains closed.

The valves are completely tubed. Control lines or similar are not required. The version for either horizontal or vertical installation can be selected.

Standard

- » ANSI or DIN flanges
- » Coating of the body: primer and top coat
- » MOD (manual opening device) for function control, bleeding or flushing
- » Vertical installation position
- » Transport lugs

Options

- » Coating as per DIN EN ISO 12944 C5-M, DIN 55633
- » Special materials such as Duplex steel
- » Various materials for O rings and seals, suitable for your medium
- » Version for horizontal installation position incl. bridge (supporting structure), position of the control element can be selected
- » Enlarged MOD „manual opening device“ for viscous media
- » Flow switch on the outlet side
- » Media separator
- » Tamper-proof adjustment elements for protection against unauthorized access
- » Exchangeable filter for the pilot system (SR 6.2P)
- » Contamination level indicator for the pilot system (SR 6.2P)
- » Special connection upon request
- » Special versions on request

Operating instructions, know how and safety instructions must be observed. The pressure has always been indicated as overpressure. We reserve the right to alter technical specifications without notice.



K_{vs} Values [m³/h]

nominal diameter DN	150	200	250	300	400
SR 6.2K	400	720	1000	1500	2000
SR 6.2P	470	850	1200	1800	2400

C_{vs} Values [US gal/min.]

nominal diameter DN	150	200	250	300	400
SR 6.2K	465	837	1183	1744	2325
SR 6.2P	547	988	1395	2093	2791

Pressure Control Valves

Surge Relief Valves SR 6.2

Surge Relief Valve (Peak Load)



Materials	
Body	steel- or CrNiMo steel welded
Inner Parts	CrNiMo steel
Pilot System	
MOD	
Valve Seal	HNBR
Piston Seal	PTFE
Piston Guide	PTFE
Pressure Springs	coated spring steel or CrNi steel

Dimensions [mm]					
size	nominal diameter DN				
	150	200	250	300	400
A*	on request				
B	on request				

* Overall length tolerances in acc. with DIN EN 558

Weights [kg]					
nominal pressure	nominal diameter DN				
	150	200	250	300	400
PN 16 - 160	on request				

Customs Tariff Number
84814010

Since the pressure relief valve SR 6.2 will be customized to your operating data and its structural shape may vary considerably, we cannot specify any detailed dimensions or weights. Please let us have your enquiry.

Special designs on request.
The pressure has always been indicated as overpressure.
Mankenberg reserves the right to alter or improve the designs or specifications of the products described herein without notice.

Dimensional Drawing

UV 6.2K

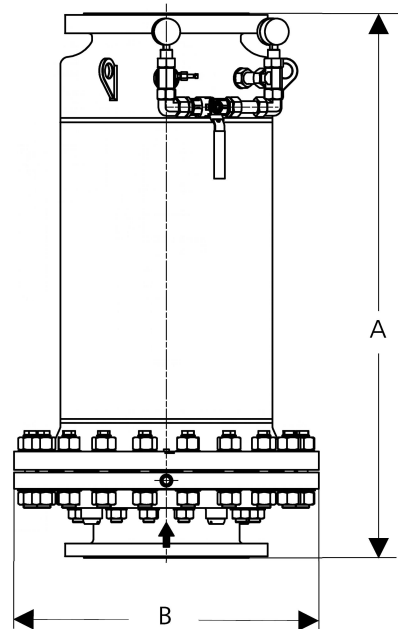

UV 6.2P

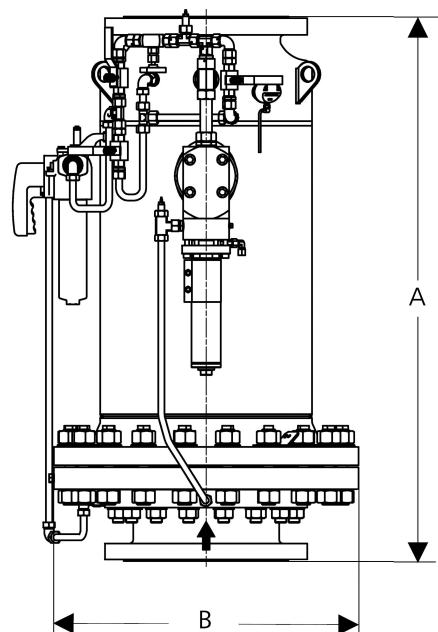

Authorised Distributor:



46, Jalan SS 22/21, Damansara Jaya,
47400 Petaling Jaya,
Selangor Darul Ehsan, Malaysia.

Email: nog@nog.com.my
Webste: www.nog.com.my