

Bleeding and venting valves

Bleeding and venting valves EB 1.20

Large sized cast bleeding and venting valve



Technical Data

Connection DN	80/65 - 200/150
Nominal pressure PN	16
Operating pressure	0 - 16 bar
Flow rate	7770 Nm ³ /h
Temperature	200 °C
Medium	liquids

Description

Bleeding and venting valves remove air or gases from systems or pipelines without requiring an external energy input. When a system is drained they act as venting valves; venting may be prevented by fitting a non-return valve.

The EB 1.20 bleeding/venting valves are float-controlled robust valves made of spherical-graphite cast iron to handle large air volumes e.g. in sand filters. The internal components are made of made of Cr/CrNiMo-steel/red brass and the float is made of CrNiMo-steel. Up to 130 °C the valve cone is fitted with a soft seal; up to 200 °C the seal is metallic.

The simple design makes it easy to specify, install, handle and service these valves in an industrial environment.

Valves for continuous bleeding must not be overdimensioned. If a larger valve size is selected, a higher working pressure range with a correspondingly lower flow volume should be chosen. In case of doubt we shall be happy to advise you.

On filter vessels the bleed connection is often located in the middle of the vessel. If the flow volume is large and the distance between distribution funnel and bleed connection small, the incoming water jet hits the bleed connection. This will impair the efficiency of the bleed valve and can result in water hammer. This problem may be avoided by installing a baffle or by placing the bleed connection away from the centre.

Options

- » Manual bleed valve made of stainless steel (CrNiMo steel)
- » Rubber or plastic coating for corrosive fluids
- » Non-return valve to prevent venting
- » Special versions on request

Operating instructions, know how and safety instructions must be observed. The pressure has always been indicated as overpressure. We reserve the right to alter technical specifications without notice.



Pressure Ranges [bar]

0 - 2	0 - 4	0 - 8	0 - 13	0 - 16
-------	-------	-------	--------	--------

Bleeding and venting valves

Bleeding and venting valves EB 1.20

Large sized cast bleeding and venting valve



Materials

Temperature	130 °C	200 °C
Body	spheroidal cast iron	spheroidal cast iron
Body Seal	Nova Universal	Nova Universal
Internals	Cr / CrNiMo-steel / Rg	Cr / CrNiMo-steel / Rg
Valve Seal	EPDM	metallic

Dimensions [mm]

size	nominal diameter DN			
	80/65	100/80	125/100	200/150
A*	460	455	500	715
B	445	425	465	735
C	550	525	580	875
øD	285	365	380	520
E	220	-	-	-

* Overall length tolerances in acc. with DIN EN 558

Weights [kg]

nominal diameter DN				
	80/65	100/80	125/100	200/150
	76	95	130	280

Customs Tariff Number

84818059

Special designs on request.

The pressure has always been indicated as overpressure.

Mankenberg reserves the right to alter or improve the designs or specifications of the products described herein without notice.

Dimensional Drawing

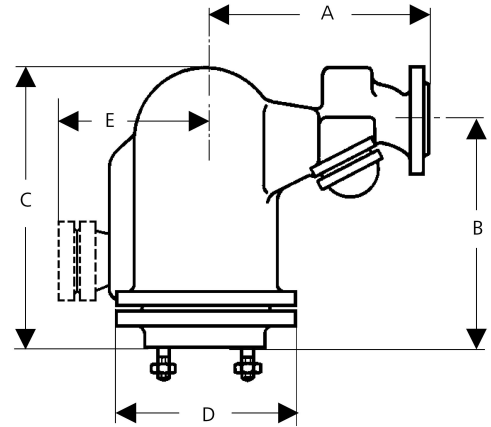

Bleeding and venting valves

Bleeding and venting valves EB 1.20



Large sized cast bleeding and venting valve

Seat Diameter [mm]				
pressure range bar	nominal diameter DN			
	80/65	100/80	125/100	200/150
0 - 2	30	40	50	78
0 - 4	24	32	40	61
0 - 8	20	24	30	46
0 - 13	16	20	24	36
0 - 16	14	18	22	36

The quoted flow volumes apply to a fully open valve i.e. in start-up condition at 0 °C and 1013 mbar. With continuous bleeding e.g. of filter vessels, the maximum flow volume is 30 % less on average.

* Please note: Smaller seat diameter for higher pressure range. If the selected working pressure range is too high, the flow volume may be inadequate.

Air Flow Rate [Nm ³ /h] up to Δp 10 bar								
seat ø mm	differential pressure Δp bar							
	0.1	0.5	1	2	4	6	8	10
8	16	35	45	67	113	157	203	248
9	21	45	57	85	143	200	258	315
10	25	55	70	106	176	246	317	388
12	37	80	102	152	254	355	457	559
14	50	109	138	207	346	484	621	760
16	66	143	180	270	451	630	811	992
18	84	181	228	342	571	800	1028	1255
20	103	224	282	424	705	988	1270	1550
22	128	256	342	513	855	1197	1540	1880
24	148	321	406	610	1020	1420	1830	2240
28	205	417	556	834	1390	1950	2500	3060
30	233	503	635	953	1590	2220	2860	
32	264	570	721	1080	1800			
36	360	678	914	1370	2285	4000	4113	5027
40	415	895	1130	1690	2820			
46	564	1170	1490	2235	3425	5215	6705	
50	646	1392	1760	2640				
61	992	2070	2624	3956	6555			
78	1517	3400	4290	6430				

Air Flow Rate [Nm ³ /h] from Δp 12 bar			
seat ø mm	differential pressure Δp bar		
	12	13	16
8	293	315	383
9	372	400	486
10	459	494	599
12	661	711	864
14	900	967	1175
16	1170	1260	1530
18	1485	1595	1940
20	1833	1975	
22	2225	2395	2900
24	2640	2845	
28	3600	3890	4315
30			
32			
36	5940	6400	7770

Special designs on request.
The pressure has always been indicated as overpressure.
Mankenberg reserves the right to alter or improve the designs or specifications of the products described herein without notice.

Authorised Distributor:



46, Jalan SS 22/21, Damansara Jaya,
47400 Petaling Jaya,
Selangor Darul Ehsan, Malaysia.

Email: nog@nog.com.my
Webste: www.nog.com.my