

Pressure control valves

Pressure reducing valves DM 762 ATEX

Millibar valve for potentially explosive atmospheres



Technical Data

Connection DN	15 - 50
Connection G	1/2 - 2
Nominal pressure PN	16
Inlet pressure	up to 16 bar
Outlet pressure	0.002 - 0.52 bar
K_{vs} value	0.2 - 3.6 m ³ /h
Temperature	130 °C
Medium	liquids and gases

Description

Self-acting pressure reducers are simple control valves offering accurate control while being easy to install and maintain. They control the pressure downstream of the valve without requiring pneumatic or electrical control elements.

The DM 762 pressure reducing valve is a diaphragm-controlled spring-loaded proportional control valve for very small outlet pressures and medium volumes in potentially explosive atmospheres. This pressure reducer is manufactured from deep-drawn stainless steel featuring excellent corrosion resistance. The valve cone is fitted with a soft seal.

The outlet pressure to be controlled is balanced across the control unit by the force of the valve spring (set pressure). As the outlet pressure rises above the pressure set using the adjusting screw, the valve cone moves towards the seat and the volume of medium is reduced. As the outlet pressure drops, the valve control orifice increases; when the pipeline is depressurised, the valve is open. Turning the handwheel clockwise increases the outlet pressure.

The valves requires a sense line (to be installed on-site).

We recommend that G 1 and G 1½ or DN 25 and DN 40 connections be used.

These valves are no shut-off elements ensuring a tight closing of the valve. In accordance with DIN EN 60534-4 and/or ANSI FCI 70-2 they may feature a leakage rate in closed position in compliance with the leakage classes V.

Standard

- » All stainless steel construction
- » Sense line connection

Special features of the ATEX version

- » Conformity to ATEX Directive 2014/34 / EU and DIN EN ISO 80079-36
- » Leakage line connection, adjusting screw seal and lock
- » Potential equalization among the valve components
- » Protected body connections
- » Grounding device at the valve body
- » Electrically conductive components

Options

- » Clean gas version with special connections
- » Various diaphragm and seal materials suitable for your medium
- » Special connections: Aseptic, ANSI or JIS flanges, NPT, welding spigots; other connections on request

Operating instructions, supplementary operating instructions, know-how and safety instructions must be strictly observed. All the pressure has been specified as overpressure. Technical data subject to change.

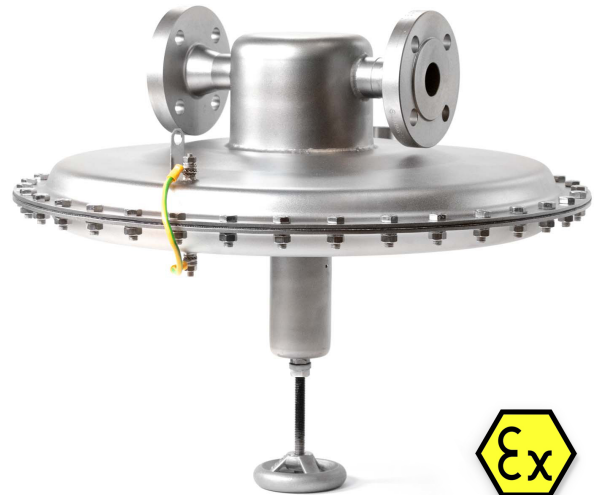

ATEX Marking

Ex II 2G Ex h IIB 85°C...130°C Gb X

K_{vs} -Values [m³/h] for all body sizes

0.2	0.9	1.5	2.2	2.8	3.6
-----	-----	-----	-----	-----	-----

Setting Ranges [bar]

Setting Ranges [bar]			diaphragm [mm]
0.002 - 0.004	0.003 - 0.015		ø 500
0.004 - 0.010	0.005 - 0.032		ø 360
0.008 - 0.016	0.015 - 0.065	0.05 - 0.28	ø 270
0.015 - 0.03	0.025 - 0.125	0.1 - 0.52	ø 220

Permissible Reduction Ratio (max. p_1/p_2)

diaphragm diameter	K_{vs} -value [m ³ /h]					
	0.2	0.9	1.5	2.2	2.8	3.6
500	15000	7500	4500	2200	1500	1100
360	8000	4000	2500	1200	800	650
270	4000	2000	1250	600	400	320
220	2200	1100	660	320	210	170

Pressure control valves

Pressure reducing valves DM 762 ATEX

Millibar valve for potentially explosive atmospheres



Materials		
Temperature	80 °C	130 °C
Body, Spring Cap, Internals, Screws	CrNiMo-steel	CrNiMo-steel
Adjusting Screw	CrNiMo-steel M10 with handwheel made of CrNi-steel	
Spring	CrNi-steel	CrNi-steel
Valve Seal	FPM	FPM
Diaphragm	NBR	EPDM

Dimensions [mm]						
size	nominal diameter G					
	1/2	3/4	1	1 1/4	1 1/2	2
A*	165	170	170	180	180	180
B	35	35	35	40	45	50
C	320	330	330	340	350	360
D	= diaphragm diameter see table pressure ranges					

Dimensions [mm]						
size	nominal diameter DN					
	15	20	25	32	40	50
A ₁ *	240	240	250	250	260	260
B	35	35	35	40	45	50
C	320	330	330	340	350	360
D	= diaphragm diameter see table pressure ranges					

* Overall length tolerances in acc. with DIN EN 558

Weights [kg]			
diaphragm diameter	nominal diameter		
	G 1/2 - 2	DN 15 - 25	DN 32 - 50
500	13	15	17
360	12.5	14.5	16.5
270	8	10	12
220	6	8	10

Customs Tariff Number
84811019

Operating instructions, supplementary operating instructions, know-how and safety instructions must be strictly observed. All the pressure has been specified as overpressure. Technical data subject to change.

Dimensional Drawing

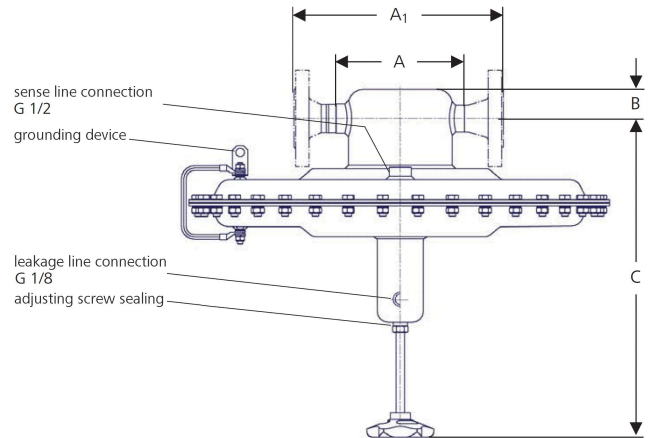

Recommended Installation

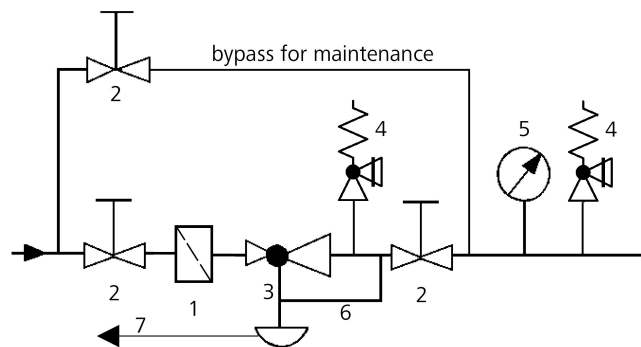

- 1 Strainer*
- 2 Shut-off Valves
- 3 Pressure Reducer*
- 4 Safety Valves*
- 5 Pressure Gauge
- 6 Sense Line G 1/2
- 7 Leakage Line G 1/8

Sense line connection 10 - 20 x DN behind the valve

*Use MANKENBERG-Products

Authorised Distributor:



46, Jalan SS 22/21, Damansara Jaya,
47400 Petaling Jaya,
Selangor Darul Ehsan, Malaysia.

Email: nog@nog.com.my
Webste: www.nog.com.my