

PRESSURE CONTROL

Pressure reducing valve DM 620

High pressure valve for medium to high flow rates

MANKENBERG

Technical data

Connection DN	15 - 50
Connection G	1/2 - 2
Nominal pressure PN	16 - 315
Inlet pressure	up to 315 bar
Outlet pressure	2 - 160 bar
K _v value	0.4 - 10 m ³ /h
Temperature	200 °C
Medium	liquids and gases
*RT	= -10 °C TO + 50 °C

Description

Self-acting pressure reducers are simple control valves offering accurate control while being easy to install and maintain. They control the pressure downstream of the valve without requiring pneumatic or electrical control elements.

The DM 620 pressure reducing valves are diaphragm-controlled spring-loaded and balanced proportional control valves for high inlet and outlet pressures. They can be supplied with three types of connections: sockets, flanges or welding spigots. Each size of valve may be fitted with three different seats. The valve cone may be fitted with a soft or metallic seal.

The outlet pressure to be controlled is balanced across the control unit by the force of the valve spring (set pressure). As the outlet pressure rises above the pressure set using the adjusting screw, the valve cone moves towards the seat and the volume of medium is reduced. As the outlet pressure drops, the valve control orifice increases; when the pipeline is depressurised, the valve is open. Rotating the adjusting screw clockwise increases the outlet pressure.

Der max. zulässige Hinterdruck beträgt - sofern nicht anders angegeben - das 1,5-fache des Einstelldruckes.

These valves are no shut-off elements ensuring a tight closing of the valve. In accordance with DIN EN 60534-4 and/or ANSI FCI 70-2 they may feature a leakage rate in closed position in compliance with the leakage classes III or V, optional IV.

Standard

- » Balanced cone for controlling the outlet pressure independently from the inlet pressure

Options

- » pressure gauge connection
- » hard-faced valve cone and seat
- » for toxic or hazardous media: sealed bonnet complete with leakage line connection (incl. sealed adjusting screw). Must be installed with a leakage line capable of draining leaking medium safely and without pressure
- » various diaphragm and seal materials suitable for your medium
- » special materials such as Duplex, Superduplex, Hastelloy® or titanium, others on request
- » special connections: ANSI or JIS flanges, NPT, welding spigots; other connections on request
- » special versions on request

Product



Picture similar

Technical specification

For more information see the attachment.

PRESSURE CONTROL

Pressure reducing valve DM 620

High pressure valve for medium to high flow rates



Materials

Materials			
Temperature	80 °C.	130 °C.	200 °C.
Body	G 1/2 - 1, DN 15 - 25 = C-steel G 1 1/4 - 2, DN 32 - 50 = steel welded optional stainless steel for all nominal diameters		
Bonnet	steel welded optional stainless steel		
Internal parts	stainless steel		
Spring	spring steel C optional stainless steel		
Soft seal	EU	EPDM optional FKM or PTFE	-
Metallic seal	stainless steel	stainless steel	stainless steel
Diaphragm	EPDM	EPDM optional FKM	-
Protection foil	PTFE (option)	PTFE (option)	-
O-ring for piston	EPDM	EPDM optional FKM or PTFE	FEPM optional PTFE
Bellow	stainless steel	stainless steel	stainless steel

Dimensions and weights

Dimensions [mm]				
size	nominal diameter			
	G 1/2	G 3/4 - 1	G 1 1/4 - 1 1/2	G 2
	DN 15	DN 20 - 25	DN 32 - 40	DN 50
A*	140	170	250	250
A ₁	220	220	280**	300**
A ₂	220	220	acc. to DIN 3202 - S14	
B	80	80	110	110
C	< 520	< 520	< 800	< 800

A₂ = Welding ends

*overall length tolerances in acc. with DIN EN 558

** Outlet pressure ≥ PN 63 on request

Weights [kg] sleeve connection, all others on request					
nominal diameter					
G 1/2	G 3/4	G 1	G 1 1/4	G 1 1/2	G 2
13	14	15	21	21	21

Customs tariff number: 84811019

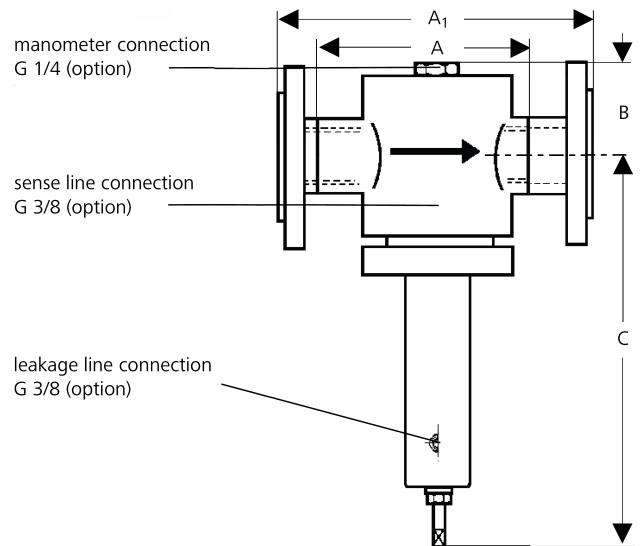

Recommended installation

- 1 Strainer
- 2 Shut-off valves
- 3 Pressure reducing valve
- 4 Safety valve
- 5 Pressure gauge
- 6 Sense line
- 7 Leakage line
- 8 Bypass

Sense line connection 10 - 20 x DN behind the valve

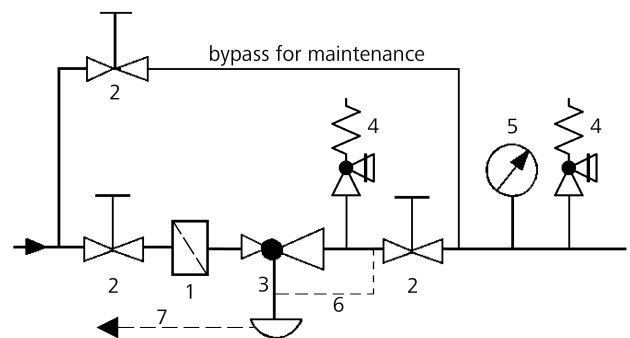

Mankenberg GmbH | Spenglerstrasse 99 | D-23556 Luebeck | Germany

Please send us your enquiry and allow us to advise you. Special designs on request.
The pressure has always been indicated as overpressure. Mankenberg reserves the right to alter technical specifications without notice.

Pressure reducing valve DM 620

High pressure valve for medium to high flow rates



Appendix

K _{vs} values [m³/h]							
nominal diameter							
G		1/2	3/4	1	1 1/4	1 1/2	2
DN		15	20	25	32	40	50
Seat	I	0.4	1.2	1.8	2.2	4.5	4.5
	II	1.2	1.8	2.2	4.5	7	7
	III	1.8	2.2	4.5	7	10	10

Setting ranges [bar], nominal pressure				
2 - 4	4 - 7	7 - 10	5 - 16	10 - 20
PN 315/6	PN 315/16	PN 315/16	PN 315/25	PN 315/40
10 - 25	20 - 35	35 - 50	45 - 63	60 - 100
PN 315/40	PN 315/63	PN 315/100	PN 315/100	PN 315/100

Permissible reduction ratio (p ₁ /p ₂)							
Setting range [bar]	Seat	nominal diameter					
		G 1/2	G 3/4	G 1	G 1 1/4	G 1 1/2	G 2
		DN 15	DN 20	DN 25	DN 32	DN 40	DN 50
2 - 4	I	160	80	60	120	58	58
	II	80	60	50	58	36	36
	III	60	50	30	36	24	24
4 - 7	I	160	80	60	78	38	38
	II	80	60	50	38	24	24
	III	60	50	30	24	16	16
7 - 10	I	64	50	42	56	28	28
	II	50	42	34	28	16	16
	III	42	34	18	16	28	28
5 - 16	I	64	50	42	66	32	32
	II	50	42	34	32	20	20
	III	42	34	18	20	14	14
10 - 20	I	53	42	35	56	28	28
	II	42	35	28	28	16	16
	III	35	28	15	16	12	12
10 - 25	I	40	36	34	36	18	18
	II	36	34	27	18	12	12
	III	34	27	14	12	8	8
20 - 35	I	32	28	26	30	14	14
	II	28	26	20	14	9	9
	III	26	20	8	9	6	6
35 - 50	I	24	20	18	22	11	11
	II	20	18	15	11	6	6
	III	18	15	7	6	5	5
45 - 63	I	19	16	14	16	8	8
	II	16	14	11	8	5	5
	III	14	11	8	5	3	3
60 - 100	I	16	14	12	16	8	8
	II	14	12	10	8	5	5
	III	12	10	5	5	3	3

Mankenberg GmbH | Spenglerstrasse 99 | D-23556 Luebeck | Germany

Authorised Distributor:



46, Jalan SS 22/21, Damansara Jaya,
47400 Petaling Jaya,
Selangor Darul Ehsan, Malaysia.
Email: nog@nog.com.my
Website: www.nog.com.my

Please send us your enquiry and allow us to advise you. Special designs on request.
The pressure has always been indicated as overpressure. Mankenberg reserves the right to alter technical specifications without notice.