

AL-1400 Diaphragm Meter

Remanufactured Meter

Elster American Meter's aluminum case meters are designed to provide positive displacement accuracy for industrial or commercial loads



Features

- Die-cast aluminum case
- Oil-impregnated, self-lubricating bushings
- Molded, convoluted diaphragms for smooth operation and long life
- Rigid, reinforced flag rods for positive alignment and sustained accuracy
- Graphite-filled phenolic valves to minimize wear
- Long-life, low friction, grommet seals
- Security seals that indicate tampering

Advantages

- Temperature compensation available from -30°F to 140°F (-34°C to 60°C)
- 1400 SCFH (39.6 m³/h) (0.60 specific gravity gas) at 1/2-inch W.C. differential
- AMR/AMI compatibility
- Meets ANSI B109.2 specifications

Applications

The AL-1400 is ideally suited for commercial and industrial installations. It is unequalled for accuracy retention and for life cycle maintenance economies.

Options

- Regular or Temperature Compensated
- Pointer or odometer index
- 5ft³, 10ft³, or 0.1m³ drive
- 2" NPT, 3" NPT and 3" flanged connection sizes
- 100 PSIG (6895 mbar) Maximum Allowable Operating Pressure (MAOP)
- Pressure compensating indexes
- Standard or UV protected index covers
- Remote Volume Pulsers



elster
American Meter

AL-1400 Diaphragm Meter

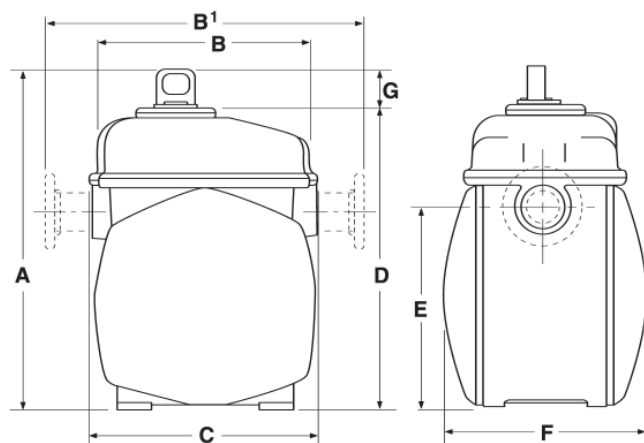

Dimensions - Inches (mm)

MAOP (PSIG)	A	B	B ¹	C	D	E	F	G	Weight (lbs.)	Connections
100	28.88 (734)	17.25 (439)		17.38 (442)	24.62 (626)	15.00 (381)	15.88 (404)	4.25 (108)	120	2" NPT (F)
100	28.88 (734)	17.25 (439)		15.75 (401)	24.62 (626)	15.00 (381)	15.88 (404)	4.25 (108)	120	3" NPT (F)
100	28.88 (734)		28.00 (712)		24.62 (626)	15.00 (381)	15.88 (404)	4.25 (108)	132	3" Flanged

Capacities (0.60 specific gravity gas)

Line Pressure PSIG (mbar)	Differential Inches W.C. (mbar)	SCFH (m ³ /h)
0.25 (17)	1/2 (1.2)	1400 (39.6)
0.25 (17)	2 (5)	3000 (85.0)
5 (345)	2 (5)	3700 (104.8)
10 (690)	2 (5)	4600 (130.3)
15 (1035)	2 (5)	5000 (141.6)
20 (1379)	2 (5)	5600 (158.6)
25 (1724)	2 (5)	6200 (175.6)
30 (2069)	2 (5)	6800 (192.6)
50 (3447)	2 (5)	9000 (254.9)
75 (5171)	2 (5)	11500 (325.6)
100 (6895)	2 (5)	13800 (390.8)

About Elster Group

A world leader in advanced metering infrastructure, integrated metering, and utilization solutions to the gas, electricity and water industries. Elster's metering and system solutions reflect over 170 years of knowledge and experience in measuring precious resources and energy.

Elster provides solutions and advanced technologies to help utilities more easily, efficiently and reliably obtain and use advanced metering intelligence to improve customer service, enhance operational efficiency, and increase revenues. Elster's AMI solutions enable utilities to cost-effectively generate, deliver, manage, and conserve the life-essential resources of gas, electricity, and water.

Elster has a staff of over 7,500 serving customers globally in North America, Central America, South America, Europe, Asia, Africa and the Middle East.

ISO 9001:2000



Certification No. 006697

Authorised Distributor:



46, Jalan SS 22/21, Damansara Jaya,
47400 Petaling Jaya, Selangor Darul Ehsan, Malaysia.

Email: nog@nog.com.my

Web access: <http://www.nog.com.my>