

AL-1000 Diaphragm Meter

Elster American Meter's aluminum case meters are designed to provide positive displacement accuracy for industrial or commercial loads.

Features

- Die-cast aluminum case
- Oil-impregnated, self-lubricating bushings
- Molded, convoluted diaphragms for smooth operation and long life
- Rigid, reinforced flag rods for positive alignment and sustained accuracy
- Graphite-filled phenolic valves to minimize wear
- Long-life, low friction, grommet seals
- Single coat polyester primer with high solids polyurethane top coat
- Security seals that indicate tampering

Advantages

- AMR/AMI Compatibility
- Temperature Compensation available from -30°F to 140°F (-34°C to 60°C)
- Meets ANSI B109.2 specifications
- Measurement Canada accredited
- 1000 SCFH (28.3m³/h) (0.60 specific gravity gas) at 1/2-inch W.C. differential

Applications

The AL-1000 meter is ideally suited for commercial and industrial installations. It is unequalled for accuracy retention and for life cycle maintenance economies.

Options

- Regular or Temperature Compensated
- Pointer or odometer index
- 5ft³, 10ft³, or 0.1m³ drive
- 30LT, 45LT, 60LT, 100LT, 1-1 1/2" NPT and other connection sizes
- Pressure compensating indexes
- Standard or UV protected index covers
- Remote volume pulsers
- Connection sets
- 25 or 100PSIG (170 or 6895 mbar) Maximum Allowable Operating Pressure (MAOP)



elster
American Meter

AL-1000 Diaphragm Meter

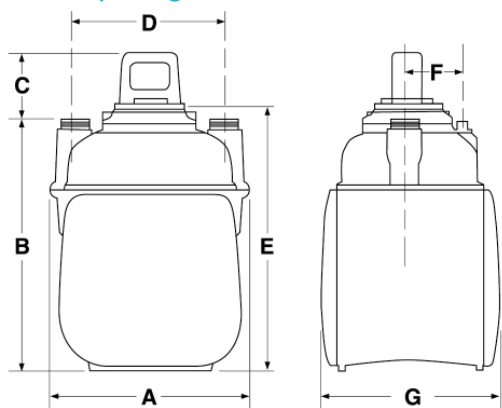

Dimensions - Inches (mm)

MAOP (psig)	A	B	C	D	E	F	G	Weight (lbs.)	Connections
25	14.12 (359)	18.50 (470)	4.81 (122)	11.00 (279)	19.12 (486)	4.38 (111)	13.25 (337)	54	1-1/2"–45 LT 1-1/2" NPT (F)
25	14.12 (359)	19.25 (489)	4.06 (103)	11.00 (279)	19.12 (486)	4.38 (111)	13.25 (337)	54	2"–100 LT
25	14.12 (359)	20.25 (514)	3.06 (78)	11.00 (279)	19.12 (486)	4.38 (111)	13.25 (337)	54	#5 Sprague
100	14.62 (372)	18.75 (476)	5.19 (132)	11.00 (279)	19.75 (502)	4.38 (111)	16.62 (422)	78	1-1/2" NPT (F)

Capacities (0.60 specific gravity gas)

Line Pressure PSIG (mbar)	Differential Inches W.C. (mbar)	SCFH (m ³ /h)
0.25 (17)	1/2 (1.2)	1000 (28.3)
0.25 (17)	2 (5)	2200 (62.3)
5 (345)	2 (5)	2700 (76.5)
10 (690)	2 (5)	3400 (96.3)
15 (1035)	2 (5)	3700 (104.8)
20 (1379)	2 (5)	4100 (116.1)
25 (1724)	2 (5)	4600 (130.3)
30 ¹ (2069)	2 (5)	5000 (141.6)
50 ¹ (3447)	2 (5)	6600 (186.9)
75 ¹ (5171)	2 (5)	8400 (237.9)
100 ¹ (6895)	2 (5)	10100 (286.0)

1 - 100 psig model only

About Elster Group

A world leader in advanced metering infrastructure, integrated metering, and utilization solutions to the gas, electricity and water industries. Elster's metering and system solutions reflect over 170 years of knowledge and experience in measuring precious resources and energy.

Elster provides solutions and advanced technologies to help utilities more easily, efficiently and reliably obtain and use advanced metering intelligence to improve customer service, enhance operational efficiency, and increase revenues. Elster's AMI solutions enable utilities to cost-effectively generate, deliver, manage, and conserve the life-essential resources of gas, electricity, and water.

Elster has a staff of over 7,500 serving customers globally in North America, Central America, South America, Europe, Asia, Africa and the Middle East.

ISO 9001:2000



Certification No. 006697

Authorised Distributor:



46, Jalan SS 22/21, Damansara Jaya,
47400 Petaling Jaya, Selangor Darul Ehsan, Malaysia.
Email: nog@nog.com.my
Web access: <http://www.nog.com.my>

© 2009 Elster American Meter. All right reserved

EAM-DS3815-EN-P - September 2009