

P seal – Paper and Pulp seal type

Design description

Badotherm P-seal is mainly used in the pulp and paper industry. The seal can handle highly viscous media with particles in the media. These kind of situations are found in the pulp production and paper processing. Unique part of this design is the rotating retainer flange.

Body / diaphragm combinations

Housing materials	Diaphragm material		
	Upper / Lower	General name	UNS
AISI 316(L)	AISI 316L	S31600	1.4404
AISI 316	AISI 316	S31600	1.4435
Duplex F51/F60	Duplex 2205	S32205	1.4462

Size and rating – DN48 PN40

Size	Rating	Type
DN48	PN40	Retaining ring with bolts

Polymer solutions

Polymer solutions come in several executions and forms. The technical data on thickness and temperature limitation can be found in datasheet “polymer solutions”. The upper part of the SJ can be executed with:

- PTFE coating
- PFA coating
- PTFE sheet

The lower parts of the P is not suitable for coating because of the welded constructions.

-> See datasheet “Polymer solutions”

Capillary tube and armor (protection)

The standard capillary mounting position is top side (axial) of the seal. The standard tube material is TP316 (316SS). There are three options in ID of the capillary; 2mm, 1mm, and 0.7mm. Badotherm capillaries are always protected against mechanical forces by armor. This doubled shielded armor consist is standard AISI 304, and optionally AISI 316. Additionally, the armor could be protected with a PVC sleeve in white, black, optionally with ATEX114 approval to protect against dust and water ingress and possibly corrosive ambient atmosphere.

-> See datasheet “Capillary lines”



Cooling options

There are several ways to protect the instrument from elevated temperatures, such as the extended direct mount (EDM), a temperature reducer (TR) or by means of capillary.

-> See datasheet “cooling devices”

Instrument connections

The P seal are designed to be direct mounted to a pressure gauges or a pressure transmitter. The leading instrument connection for the P seals is G ½. However for vibrating application that are remoted mounted with a mounting bracket, a capillary a top mounted execution is available.

Gaskets

Gaskets for the P can be supplied by Badotherm and is made out of PTFE.

Retaining bolts & nuts

The retaining bolts between upper and lower part can be selected in different materials and are in the size M6.

Grade bolt	Grade nut	Material
ISO 3506-1 A2-70	ISO 3506-2 A2	AISI 304
ISO 3506-1 A4-70	ISO 3506-2 A4	AISI 316

Material Certification

Material traceability and related certification are applicable for all process wetted parts. Material certification possibilities depend on the type of seal, the assembly construction and the materials used. Material certification is in accordance with EN10204 3.1.

Additional material certification and testing can be provided on request, such as Positive Material Identification (PMI), Intergranular corrosion (IGC) testing, material certification in accordance with EN10204 3.2, NACE conformity for ISO-15156 (MR-0175) and/or ISO-17945 (MR-0103), NORSOK M-630 and many more.

-> Please note that the responsibility for material selection always rests with the user.

Flange Marking & Traceability

All flanges are marked by the forging shop with heat number, material designation, size, and rating. Badotherm adds a Badotherm reference number and the manufacturers name to the flange for traceability purposes.

Flanges and origin

The seal parts are made from forged materials according to the applicable standards. The standard sourcing of flanges is of international origin. Optionally regional preference can be requested, for example materials from EU origin.

Testing

All seals are helium tested according the EN 13185 test procedure A.3 up to 10^{-9} mbar l/s before used on a diaphragm seal application.

-> See datasheet "Diaphragm Seal testing"

Cleanliness of the wetted parts

All parts are standard cleaned from excessive oil and grease. When additional requirements are needed, the parts can be cleaned according customer requirements and cleaning specifications.

Example performance calculation

Whether a diaphragm seal can be used for a specific measurement, depends on the size of the diaphragm. That size is restricted by the size of the diaphragm seal.

For pressure transmitters, Badotherm offers an online performance calculation tool to calculate its performance and to ensure that the diaphragm size is suitable for your measurement.

The table below presents the minimum span of the respective diaphragm sizes with standard process conditions. As rule of thumb, a TPE of max 5% is often considered acceptable, but it depends per situation.

Minimum span table

dD	AP/GP	DP
44mm	1575 mbar	255 mbar

Pressure transmitter; ambient temperature -10...+30°C; process temperature 100°C with BSO 22 fill fluid; 3 meter capillary; ID 1mm, DP both sides mounted with seal

See the general overview of all diaphragm sizes with several standard situations and in combination with Badotherm pressure gauges.

Dimensions table: Seal P

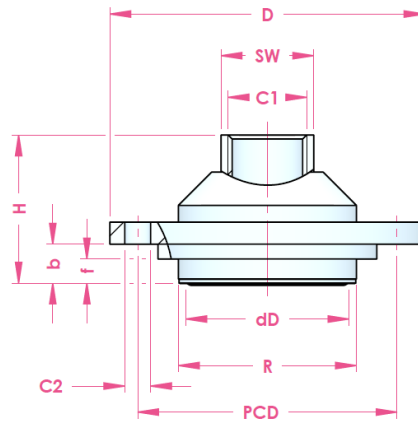

Size	rating	C1	dD	b	f	R	D	H	SW	PCD	C2
DN48	PN40	G ½	44.0	10.5	6.5	48.0	85.0	48.5	25	70.0	7.0
				19.0	15.0						

Dimensions table: Lower part P seal

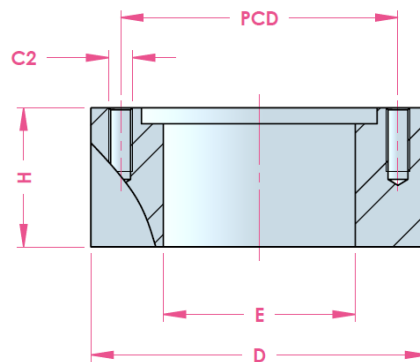

Size	rating	D	E	H	PCD	C2
DN48	PN40	85.0	48.5	35.0	70.0	6x M6

Authorised Distributor:

46, Jalan SS 22/21, Damansara Jaya,
47400 Petaling Jaya,
Selangor Darul Ehsan, Malaysia.

Email: nog@nog.com.my

Website: www.nog.com.my

Holland – Romania – India – Thailand – Dubai – USA

To our knowledge, the information contained herein is accurate as of the date of this document. However neither Badotherm, nor its affiliates makes any warranty, express or limited, or accepts any liability in connection with this information or its use. This information is for technical skilled persons at their own discretion and risk and does not relate to the use of this product in combination with any other product. The user alone finally determines suitability of any information or material in contemplated use, the manner of use and whether any patents are infringed. This information gives typical properties only. Badotherm reserves the right to make changes to the specifications any materials without prior notice. The latest version of the datasheet can be found on www.badotherm.com.

© 2015 Badotherm, all rights reserved. Trademarks and/or other products referenced herein are either trademarks or registered trademarks of Badotherm.

DSS 7022.02

July 22