

**VAMEN**

de españa, s.a.

VALVULAS DE MARIPOSA Y ACCIONAMIENTOS  
ENGINEERED BUTTERFLY VALVES



**Butterfly Valves**





**VAMEIN DE ESPAÑA, S.A.** is an internationally well known leader company dedicated to the manufacture of Butterfly Valves and Actuators since 1970. Thanks to their wide experience, technical and human resources, **VAMEIN** offers a high quality product appropriated for the needs of the customer.

Steady modernization in production center, technical office and quality assurance system enable **VAMEIN DE ESPAÑA, S.A.** to supply products with certified guarantee. The Quality System of **VAMEIN DE ESPAÑA, S.A.** has been approved to design and manufacture butterfly valves according to ISO 9001:2008 standard and meets the requirements of the Pressure Equipment Directive 97/23/EC, Annex III, Module H of the European Economic Community.

Besides, **VAMEIN** also has European Directive ATEX 94/9/EC, concerning equipment and protective systems intended for using in potentially explosive atmospheres.

Fields of application for **VAMEIN** products are very diversified. This has given the possibility to develop a wide range of products with high reliability, covering practically all segments of the market where it is necessary to work with liquids, gases and high-density /powder products, at different pressures and temperatures bearing always in mind the respect towards the environment.

## Introduction

Main features	4
Applications and certifications	5
Applicable regulations	6

## Standard manufacture range

100 Series: Wafer type	8
160 Series: Wafer Light type	10
200 Series: Flanged type	12
500 Series: Lug type	14

## Manual actuators

Lever	16
Gear Box	17

## Automatic Actuators

Electric	18
Pneumatic	20

## Seat liners

Design	21
Codes and temperatures	21

## Hydraulic features

Kv (m <sup>3</sup> /hour) Values	22
----------------------------------	----

## Torque table

23

## Bolting list

DIN PN-10 STANDARD	24
DIN PN-16 STANDARD	25
ANSI B16.5 Class 150 Lbs. STANDARD	26
ASME B16.47 Class 150 Lbs. A-SERIES. STANDARD	26

## Key figures

27



## General advantages of butterfly valves:

- ✓ Low-pressure drop, consequently energy saving.
- ✓ Lower weight and dimensions than other types of valves.
- ✓ Maximum purchase benefits and low maintenance.
- ✓ Easy and safe operation.
- ✓ Only disc and liner are in contact with the fluid.

## Advantages of the exclusive VAMEIN design, complementary to the general ones of butterfly valves

- ✓ Quality compliance to ISO 9001:2008
- ✓ Total and permanent water tightness up to 16 bar.
- ✓ No gaskets necessary for installation between flanges.
- ✓ Maintenance free.
- ✓ Liners easy to replace.
- ✓ Due to the design with no pins, screws or keys and narrow machining tolerances of its components all parts of the valve are interchangeable.
- ✓ Extreme low operating torque.
- ✓ Possibility to use it as control (regulating) valve.
- ✓ Self-cleaning.
- ✓ Cavity free.
- ✓ Thanks to the centring holes enabling a correct alignment and a fast installation easy to place in the pipeline.
- ✓ Enables the use of insulation in heat-resistant installations.
- ✓ Quality identification for material: each body, disc and liner is marked with its code number to have a perfect quality traceability of the materials used for their production. Thus with the Heath Number our Quality Assurance Department obtain a perfect traceability of the quality of materials, enabling them to know at any time the chemical composition and mechanical properties.
- ✓ Descriptive label indicating: name of manufacturer, valve figure description, maximum working pressure, maximum working temperature, flange standard and country of origin.
- ✓ Packing in individual plastic bags up to DN 300 (12").
- ✓ Possibility of EC marking as per the Pressure Equipment Directive 97/23/EC and European Directive ATEX 94/9/EC on equipments and protective systems intended for use in explosive atmospheres.

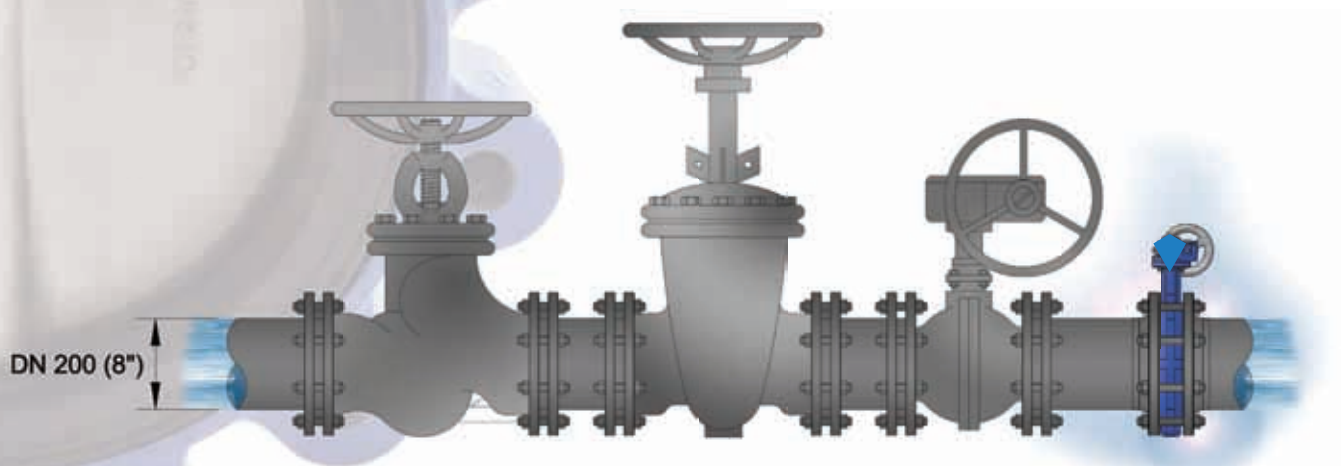

VALVE TYPE	GLOBE	GATE	BALL	BUTTERFLY
APPROXIMATE WEIGHT	165 Kg	145 Kg	80 Kg	17 Kg
FACE TO FACE	600 mm	600 mm	230 mm	60 mm

# Applications and certifications

The VAMEIN butterfly valve has many uses in many different fields. The following list contains some of the different types of industries and fluids that our valves are used for:

INDUSTRIES	
Air and gas conductors	Mining
Cement Factories	Nuclear Power Stations
Chemical Industry	Oil Refinery
Combined Cycles	Paper Industry
Dairies	Power Stations
Dams and water Pumping Stations	Purifying plants
Desalination of sea water	River diversion
Destileries	Sea water desalination
Fire-prevention systems	Sugar Refineries
Food industry	Vacuum installations
Heating and air conditioning	Water treatment and piping
Iron and steel Industry	Wine Industry
Irrigation	Lorry tankers
	Etc

FLUIDS	
Acids	Gases
Air	Hydrogen
Beer	Kerosene
Concrete	Milk
Chlorine	Oils
Demineralised water	Oxygen
Dissolvents	Ozone
Drinking water	Paints
Fats	Petroleum
Fluor	Raw oil
Fruit juices	Sea water
Fuels	Sewage
Wine	Water steam

## ATEX: EC TECHNICAL FILE RECEIPT

**Lloyd's Register**  
**EC TECHNICAL FILE RECEIPT**

This is to certify that Lloyd's Register Certification, a Notified Body under the terms of Protective Systems intended for use in Potentially Explosive Atmospheres Directive (ATEX) and Protection Systems intended for use in Potentially Explosive Atmospheres Regulation (ATEX) 2014/54/EU, is complying with the requirements of the Conformity Assessment under Article 8 (Annex III) of the Directive (and Regulation 30 (2010/67) of the LR for retention a Technical File as attached below:

This receipt is issued to:

APPLICANT: **VAMEIN DE ESPAÑA, S.A.**  
 C/ Temple, 1  
 28700 Tres Cantos  
 Madrid (Spain)

TECHNICAL FILE DESCRIPTION:  
 Wafer, flanged and lug type butterfly valves for nominal DN50 to DN1200 (2" to 48") and PN10 to P7

TECHNICAL FILE REFERENCE: **AT-001, fecha 17-05-2009**

The file will be stored for an initial period of five years from date of receipt, 10 years and the file will be either returned or destroyed, or a new extension

This receipt must be produced by the manufacturer to include the stored file

Storage No: **0038/ATEX/000007**  
 Date of Receipt: **24 June 2009**  
 LRX Notified Body Number **0094**

*B. Almona on left*

Copyright: Industrial Design & Product 1

## EC CERTIFICATE OF CONFORMITY

**Lloyd's Register**  
**Lloyd's Register España, S.A.**  
 Notified Body N° 0094

**EC CERTIFICATE OF CONFORMITY**

In accordance with the requirements of R.D. 769/1999 which transpose the Pressure Equipment Directive 97/23/CE

This is to Certify that the Quality Management System of:

**VAMEIN DE ESPAÑA, S.A.**  
 Pol. Ind. Tres Cantos  
 28700 Tres Cantos (Madrid)  
 Spain

has been assessed against the requirements of Annex III Module H of the Pressure Equipment Directive 97/23/CE schedule and conforms to the requirements for the product shown below:

**Design and production of wafer, flanged and lug type butterfly valves in ductile iron, carbon steel, stainless steel and bronze, for nominal diameters from DN-50 to DN-1200 (DN-2" to 48") and nominal pressures PN 10 and PN 16**

Approval is subject to the continued maintenance of Quality System in accordance with the requirements of the above Directive and Regulations

Authorisation is hereby given to use the LR Notified Body Identification Number 0094 (Princesa 29, 1° Madrid - Spain) in accordance with the requirements of specified Directive and Regulations in relation to the products as identified above

Certificate N°: **009**  
 Original Approval: **30/05/2002**  
 11/05/2008

**Lloyd's Register**

## CERTIFICATE ISO 9001:2008

**Lloyd's Register**  
**CERTIFICATE OF APPROVAL**

This is to certify that the Quality Management System of:

**VAMEIN DE ESPAÑA, S.A.**  
 Tres Cantos, Madrid  
 Spain

has been approved by Lloyd's Register Quality Assurance to the following Quality Management System Standards:

**ISO 9001:2008**

The Quality Management System is applicable to:

**Design and production of wafer, flanged and lug type butterfly valves for nominal diameters from dn 50 to dn 1200 (dn 2" to dn 48").**

Approval Certificate No: **SGR 2202107**

Original Approval: **17 May 2002**  
 Current Certificate: **15 December 2009**  
 Certificate Expiry: **14 December 2012**

*[Signature]*  
 Issued by: **LRQA, LMI, Operaciones España**

**LLOYD'S REGISTER QUALITY ASSURANCE**  
**UKAS QUALITY MANAGEMENT**  
 001

# Applicable regulations

## CONCERNING QUALITY SYSTEM

CODE	TITLE
UNE-EN-ISO 9001:2008	Quality management systems. Requirements.
97/23/EC	European Directive 97/23/EC concerning pressure equipment.
ATEX 94/9/EC	European Directive concerning equipment and protective systems intended for use in potentially explosive atmospheres.

## CONCERNING DESIGN

CODE	TITLE
API 609-97	Butterfly Valves: Double Flanged, Lug-and Wafer-Type.
EN-593	Industrial valves. Metallic butterfly valves.
MSS SP-67-95	Butterfly valves.
ASME/ANSI B16.24-01	Cast copper alloy pipe flanges and flanged fittings.
ASME/ANSI B16.34-96	Valves-Flanged, threaded, and welding end.
ASME/ANSI B16.42-98	Ductile Iron pipe flanges and flanged fittings.

## CONCERNING ASSEMBLY BETWEEN FLANGES

CODE	TITLE
EN 1092-1	Flanges and their joints. Circular flanges for pipes, valves, fittings and accessories, PN designated. Part I: Steel flanges.
EN 1092-2	Flanges and their joints. Circular flanges for pipes, valves, fittings and accessories, PN designated Part 2: Cast iron flanges.
ANSI B 16.5	Pipe flanges and flanged fittings: NPS ½ through NPS 24. (DN 15 through DN 600)
ANSI B 16.1	Cast iron pipe flanges and flanged fittings classes 25, 125, and 250.
ASME B 16.47	Large diameter steel flanges NPS 26 through NPS 60. (DN 650 through DN 1500)

## CONCERNING PRODUCTION - ACTUATOR COUPLING

CODE	TITLE
UNE-EN-ISO 5211-01	Industrial valves. Part-turn valve actuator coupling.

### DN 50-300 mm (2"- 12")

- Standard Vamein dimensions with parallel square to 0° (two faces of square parallel to the disc) with dimensions to UNE-EN-ISO 5211 and DIN 79 standards.
- Optionally, with diagonal square to 45° (vertexes of the square in line with the disc) with dimensions to UNE-EN-ISO 5211 and DIN 79 standards.

N.B.: From DN 50-200mm., the central groove on the top flange, as per UNE-EN-ISO 5211, is special construction.



# Applicable regulations

## DN 350-1200 (14"- 48"):

- Standard Vamein dimension with key-way shaft end to ISO/R 773.
- Optionally, with parallel or diagonal square with dimensions to UNE-EN-ISO 5211 and DIN 79 standards.

### CONCERNING PRODUCTION - FACE TO FACE DN 50-500 (2" - 20")

CODE	TITLE
UNE-EN 558-1-96	Industrial valves. Face-to-face and centre-to-face dimensions of metal valves for use in flanged pipe systems. Part 1 PN-designated valves.
UNE-EN 558-2-96	Industrial valves. Face-to-face and centre-to-face dimensions of metal valves for use in flanged pipe systems. Part 2 Class-designated valves.
ISO 5752-82	Metal valves for use in flanged pipe systems – Face-to-face and centre-to-face dimensions.

### CONCERNING PRODUCTION - FACE TO FACE DN 600-1200 (24" - 48")

CODE	TITLE
VAMEIN	Standard manufacture

### CONCERNING TESTING

CODE	TITLE
ISO 5208-93 (DIN 3230)	Technical delivery conditions for valves. Compilation of test methods.

### CONCERNING MARKING AND LABELLING

CODE	TITLE
UNE-EN 19-93 (ISO-5209)	Marking of general purpose industrial valves.

### CONCERNING MATERIAL AND TEST CERTIFICATES

CODE	TITLE
EN 10204	2.2 / 3.1



# Standard manufacture range 100 Series Wafer Type

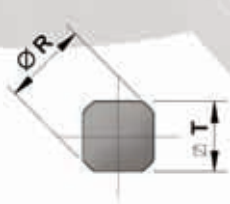
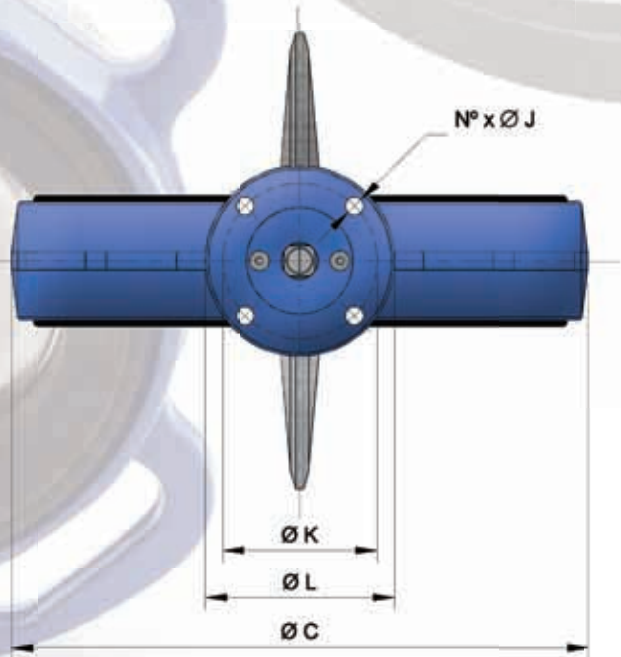
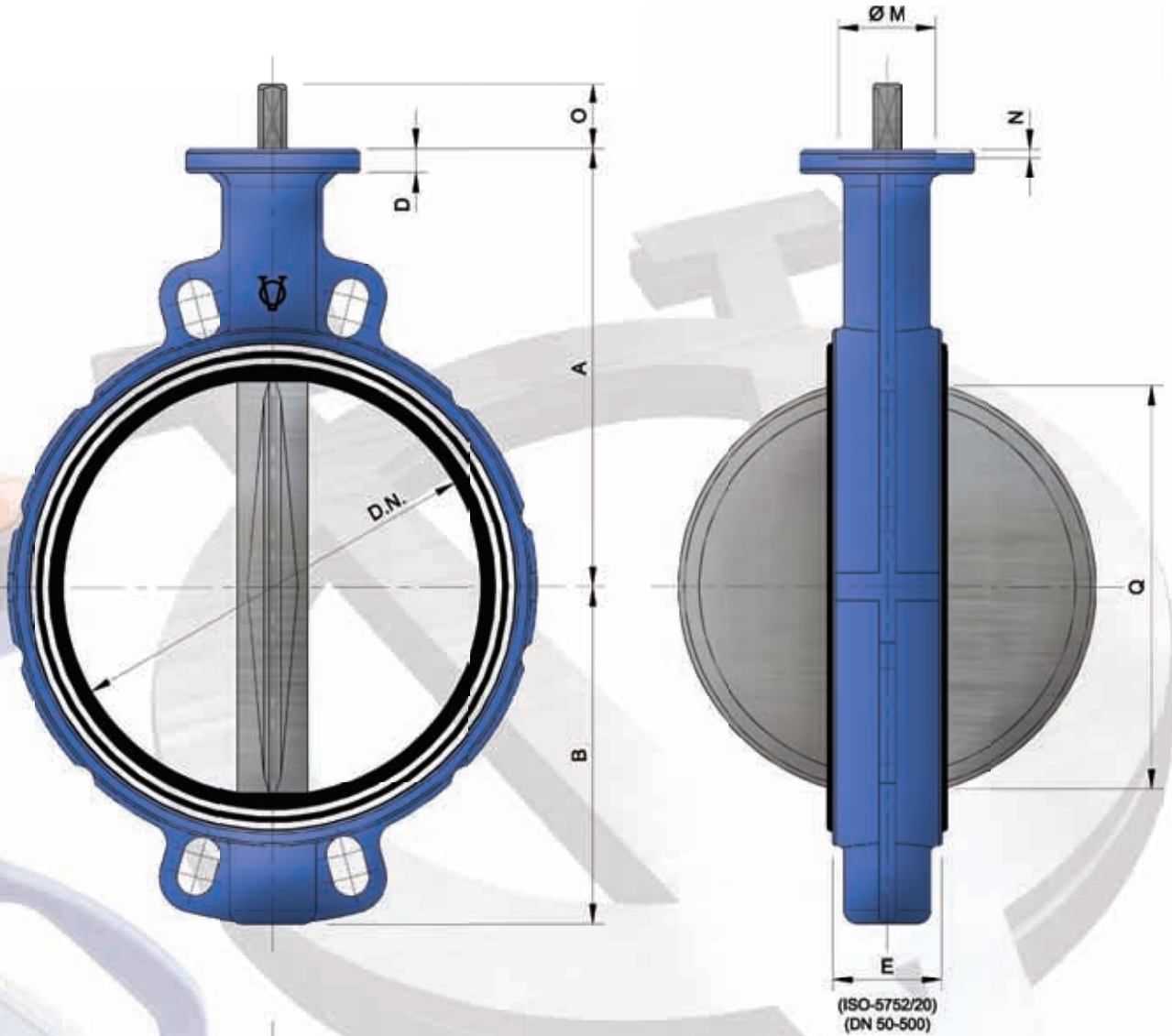

SQUARE  
(DN 50-300)



KEYWAY(1)  
(DN 350-1200)





# Standard manufacture range

## 100 Series Wafer Type

### Features

- ✓ Nominal diameters from 50 mm (2") to 2000 mm (80").
- ✓ Assembly between flanges : From DN 50 (2") to DN 300 (12") multiflange system, permitting with only one model of valve the assembly between PN-6, PN-10, PN-16, ANSI 125/150 Lbs, and B.S. 10-D/E flanges. From DN 350 (14"), assembly between DIN PN-10, PN-16 and ANSI 125/150. (for other drilling standards, please ask).
- ✓ Standard working pressure 16 Bar (DN 50-300) and 10 Bar (DN 350-2000) for higher pressures, ask our Technical Department.
- ✓ Temperature limits from -40°C to +180°C (depending on type of liners and coatings).
- ✓ 4 centering holes up to DN 500 for a correct alignment and quick installation.
- ✓ As this is a design to be used between flanges, the mechanical stress of the pipe is transferred to the valve only by compression on the body and therefore, there are not traction mechanical stress.
- ✓ Furthermore, as from DN 600 there are 4 threaded holes per each side of the body, according to the drilling standard required. This must be taken into consideration due to the traction.

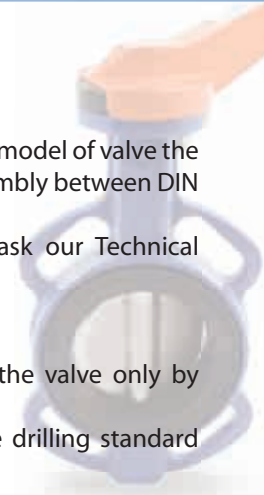

### DIMENSIONS

DN		BODY DIMENSIONS					ASSEMBLY FLANGE							SHAFT END					"Q"	WEIGHT (Kg)	
mm	Inch	A	B	Ø C	D	E	ISO-5211/2	N°	Ø J	Ø K	Ø L	Ø M <sup>(2)</sup>	N <sup>(2)</sup>	O	Ø R	Ø T	U	V			
50	2"	140	83	102	12	43	F-07	4	9	70	90	55	3	26	13.2	11				32	3.3
65	2½"	152	93	122	12	46	F-07	4	9	70	90	55	3	26	13.2	11				51	4.0
80	3"	159	98	139	12	46	F-07	4	9	70	90	55	3	26	13.2	11				69	4.3
100	4"	178	111	159	14	52	F-07	4	9	70	90	55	3	30	16.8	14				89	5.7
125	5"	191	127	189	14	56	F-07	4	9	70	90	55	3	30	16.8	14				115	7.4
150	6"	203	143	214	15	56	F-07	4	9	70	90	55	3	33	20.4	17				143	8.9
200	8"	245	172	269	15	60	F-07	4	9	70	90	55	3	33	20.4	17				194	13.5
250	10"	275	204	331	17	68	F-10	4	11	102	125	70	3	47	28	22				243	22.8
300	12"	315	242	380	17	78	F-10	4	11	102	125	70	3	47	28	22				293	31.7
350	14"	307	291	442	22	78	F-12	4	13	125	150	85	3	55	36		10	4.7		332	43.2
400	16"	342	325	493	24	102	F-14	4	17	140	175	100	4	65	42		12	4.9		382	65.2
450	18"	387	357	544	27	113	F-14	4	17	140	175	100	4	65	48		14	5.5		432	84.5
500	20"	425	381	601	27	126	F-14	4	17	140	175	100	4	65	48		14	5.5		478	119
600	24"	532	488	695	40	146	F-25	8	18	254	300	200	5	110	72		20	7.4		585	281
650	26"	550	493	736,5	40	175	F-25	8	18	254	300	200	5	110	72		20	7.4		619	348
700	28"	573	506	798	40	175	F-25	8	18	254	300	200	5	110	72		20	7.4		683	414
750	30"	622	555	872	40	176	F-25	8	18	254	300	200	5	110	72		20	7.4		733	508
800	32"	650	578	908	40	215	F-25	8	18	254	300	200	5	110	72		20	7.4		755	572
900	36"	707	643	1004	40	246	F-25	8	18	254	300	200	5	110	98		28	9.9		852	639
1000	40"	755	729	1114	40	280	F-25	8	18	254	300	200	5	110	98		28	9.9		958	918
1050 <sup>(3)</sup>	42"	781	755	1196	40	280	F-25	8	18	254	300	200	5	110	98		28	9.9		1013	1034
1100 <sup>(3)</sup>	44"	800	774	1220	40	280	F-25	8	18	254	300	200	5	110	98		28	9.9		1050	1150
1200	48"	900	855	1330	50	360	F-30	8	22	298	350	230	5	130	120		32	11.1		1098	1760

Dimensions in mm are orientative

VAMEIN DE ESPAÑA, S.A. reserves the right to modify dimensions with no previous advise.

For DN >1200 please ask.

(1): For DN 1200, two keyways in line.

(2): Central recess Ø M x N optional in DN 50-200.

(3): Special manufacture valves. Ask for availability.

Standard manufacture range

# 160 Series Wafer Light Type

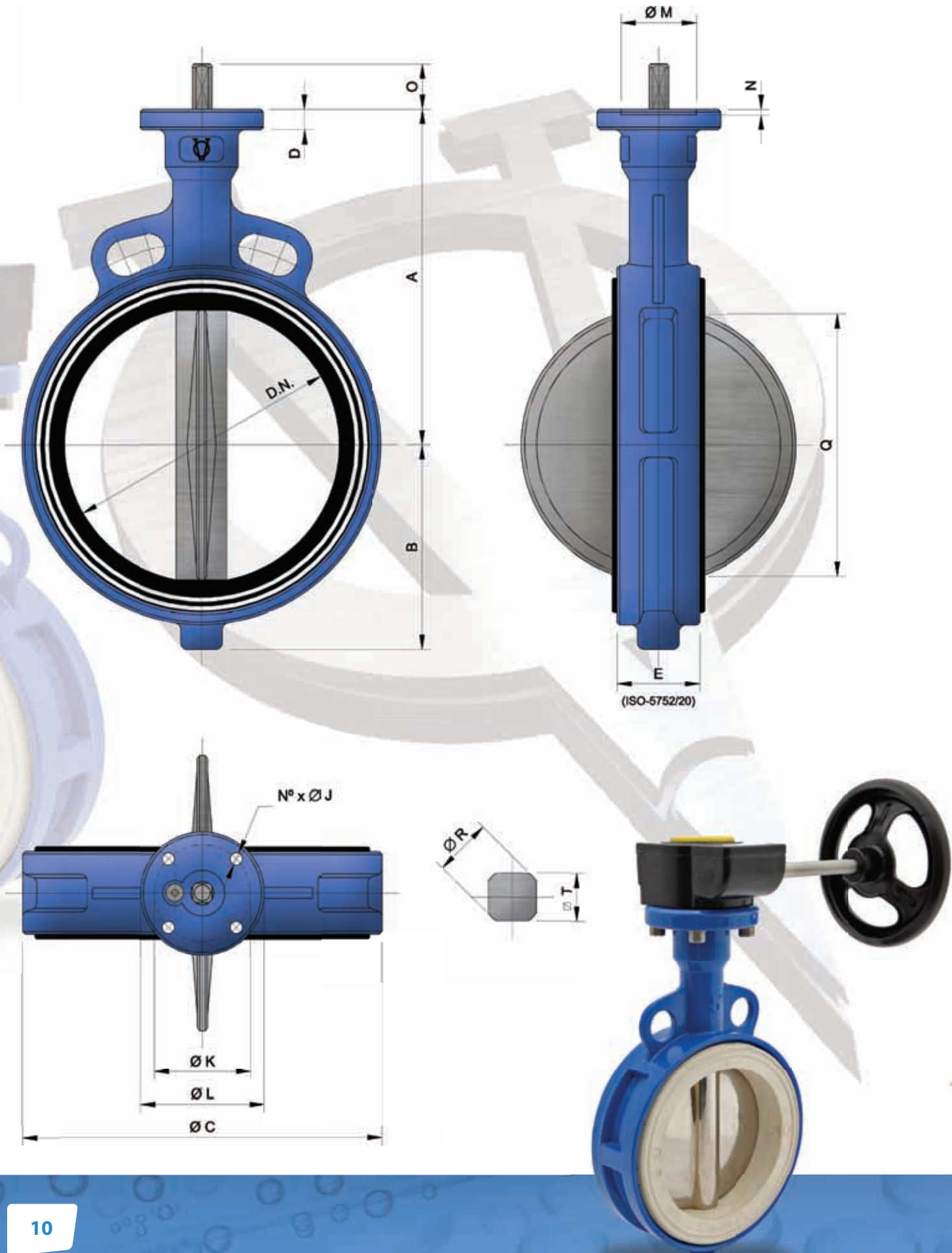



# Standard manufacture range

## 160 Series Wafer Light Type

### Features

- ✓ Nominal diameters from 50 mm (2") to 300 mm (12").
- ✓ Assembly between flanges : From DN 50 (2") to DN 300 (12") multiflange system, permitting with only one model of valve the assembly between PN-6, PN-10, PN-16, ANSI 125/150 Lbs, and B.S. 10-D/E flanges.
- ✓ Standard working pressure 10 bar.
- ✓ Temperature limits from -40°C to +180°C (depending on type of liners and coatings).
- ✓ 2 centering holes from DN 50 to DN 200 and 4 centering holes for DN 250 and DN 300 for a correct alignment and quick installation.
- ✓ As this is a design to be used between flanges, the mechanical stress of the pipe is transferred to the valve only by compression on the body and, therefore, there are not traction mechanical stress.
- ✓ The WAFER LIGHT series was developed due to the needs of de market of one light weight valve and at the same time with a low price.
- ✓ Suitable for watering, air-conditioning and swimming pool installations.

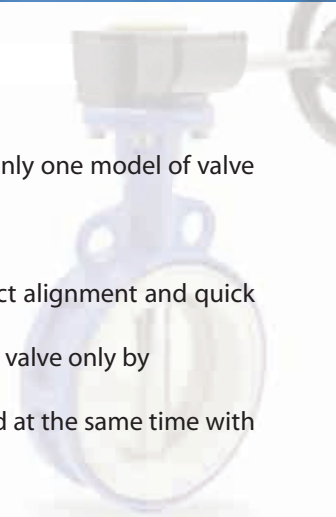

### DIMENSIONS

DN		BODY DIMENSIONS					ASSEMBLY FLANGE							SHAFT END			"Q"	WEIGHT (Kg)
mm	Inch	A	B	Ø C	D	E	ISO-5211/2	Nº	Ø J	Ø K	Ø L	Ø M(1)	N(1)	O	Ø R	∅		
50	2"	140	55	95	12	43	F-07	4	9	70	90	55	3	26	13.2	11	32	1.2
65	2½"	152	65	114	12	46	F-07	4	9	70	90	55	3	26	13.2	11	51	1.5
80	3"	159	73	131	12	46	F-07	4	9	70	90	55	3	26	13.2	11	69	1.7
100	4"	178	87	152	14	52	F-07	4	9	70	90	55	3	30	16.8	14	89	2.3
125	5"	191	102	182	14	56	F-07	4	9	70	90	55	3	30	16.8	14	115	3.5
150	6"	203	118	209	15	56	F-07	4	9	70	90	55	3	33	20.4	17	143	4.7
200	8"	245	149	262	15	60	F-07	4	9	70	90	55	3	33	20.4	17	194	7.0
250	10"	275	200	331	17	68	F-10	4	11	102	125	70	3	47	28	22	243	14.3
300	12"	315	227	380	17	78	F-10	4	11	102	125	70	3	47	28	22	293	19.8

Dimensions in mm are orientative

VAMEIN DE ESPAÑA, S.A. reserves the right to modify dimensions with no previous advise.

(1): Central recess Ø M x N optional in DN 50-200.



# Standard manufacture range

## 200 Series Flanged Type

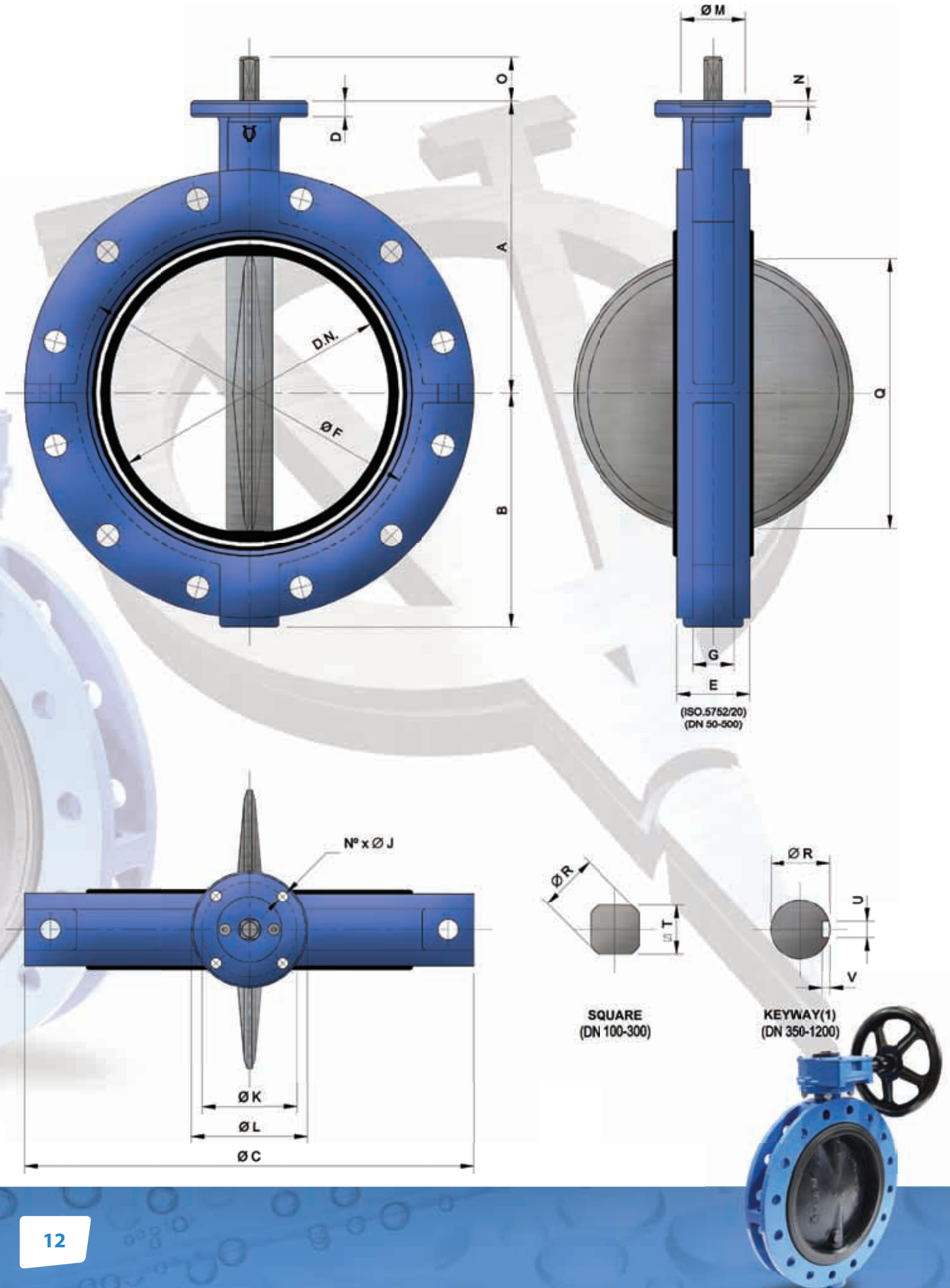



# Standard manufacture range

## 200 Series Flanged Type

### Features

- ✓ Nominal diameters from 100 mm (2") to 2000 mm (80").
- ✓ Assembly between flanges to DIN PN-10, PN-16 and ANSI 125/150. (for other drilling standards, please ask).
- ✓ Standard working pressure 16 bar (DN 100-300) and 10 bar (DN 350-2000) for higher pressures, ask our Commercial Department.
- ✓ Temperature limits from -45°C to +200°C (depending on type of liners and coatings).
- ✓ Integral drilling making the installation time shorter and enabling the perfect alignment of the valve with the pipe flanges.
- ✓ As this is a design to be used between flanges, the mechanical stress of the pipe is transferred to the valve only by compression on the body and, therefore, there are not traction mechanical stresses.
- ✓ 4 threaded holes per each side of the body as from DN 600, according to the drilling standard required. This must be taken into account.

### DIMENSIONS

DN		BODY DIMENSIONS							ASSEMBLY FLANGE							SHAFT END					"Q"	WEIGHT (Kg)	
mm	Inch	A	B	Ø C	D	E	Ø F	G	ISO-5211/2	Nº	Ø J	Ø K	Ø L	Ø M <sub>(1)</sub>	N <sub>(1)</sub>	O	Ø R	Ø T	U	V			
100	4"	178	120	229	14	52	152	32	F-07	4	9	70	90	55	3	30	16.8	14				89	10.3
125	5"	191	132	254	14	56	182	32	F-07	4	9	70	90	55	3	30	16.8	14				115	13.6
150	6"	203	148	285	15	56	207	32	F-07	4	9	70	90	55	3	33	20.4	17				143	17.3
200	8"	245	180	343	15	60	262	37	F-07	4	9	70	90	55	3	33	20.4	17				194	22.5
250	10"	275	211	406	17	68	323	38	F-10	4	11	102	125	70	3	47	28	22				243	38.8
300	12"	315	251	483	17	78	373	44	F-10	4	11	102	125	70	3	47	28	22				293	50.3
350	14"	307	291	535	22	78	425	44	F-12	4	13	125	150	85	3	55	36		10	4.7	332	66.7	
400	16"	342	325	597	24	102	475	62	F-14	4	17	140	175	100	4	65	42		12	4.9	382	98.7	
450	18"	387	357	635	27	113	530	65	F-14	4	17	140	175	100	4	65	48		14	5.5	432	128.6	
500	20"	425	381	715	27	126	587	67	F-14	4	17	140	175	100	4	65	48		14	5.5	478	171.1	
600	24"	532	488	840	40	146	680	90	F-25	8	18	254	300	200	5	110	72		20	7.4	585	304	
650	26"	550	493	870	40	175	730,5	103	F-25	8	18	254	300	200	5	110	72		20	7.4	619	380	
700	28"	573	506	927	40	175	792	103	F-25	8	18	254	300	200	5	110	72		20	7.4	683	456	
750	30"	622	555	984	40	176	862	96	F-25	8	18	254	300	200	5	110	72		20	7.4	733	556	
800	32"	657	583	1060	40	215	902	135	F-25	8	18	254	300	200	5	110	72		20	7.4	755	608	
900	36"	707	643	1168	40	246	998	166	F-25	8	18	254	300	200	5	110	98		28	9.9	852	745	
1000	40"	755	729	1255	40	280	1108	190	F-25	8	18	254	300	200	5	110	98		28	9.9	958	1038	
1050 <sub>(3)</sub>	42"	781	755	1346	40	280	1190	190	F-25	8	18	254	300	200	5	110	98		28	9.9	1013	1364	
1100 <sub>(3)</sub>	44"	800	774	1403	40	280	1220	176	F-25	8	18	254	300	200	5	110	98		28	9.9	1050	1690	
1200	48"	900	855	1511	50	360	1320	244	F-30	8	22	298	350	230	5	130	120		32	11.1	1098	1880	

Dimensions in mm are orientative

VAMEIN DE ESPAÑA, S.A. reserves the right to modify dimensions with no previous advise.

For DN > 1200, please ask.

(1): For DN 1200, two keyways in line.

(2): Central recess Ø M x N optional in DN 50-200.

(3): Special manufacture valves. Ask for availability.

# Standard manufacture range 500 Series Lug Type

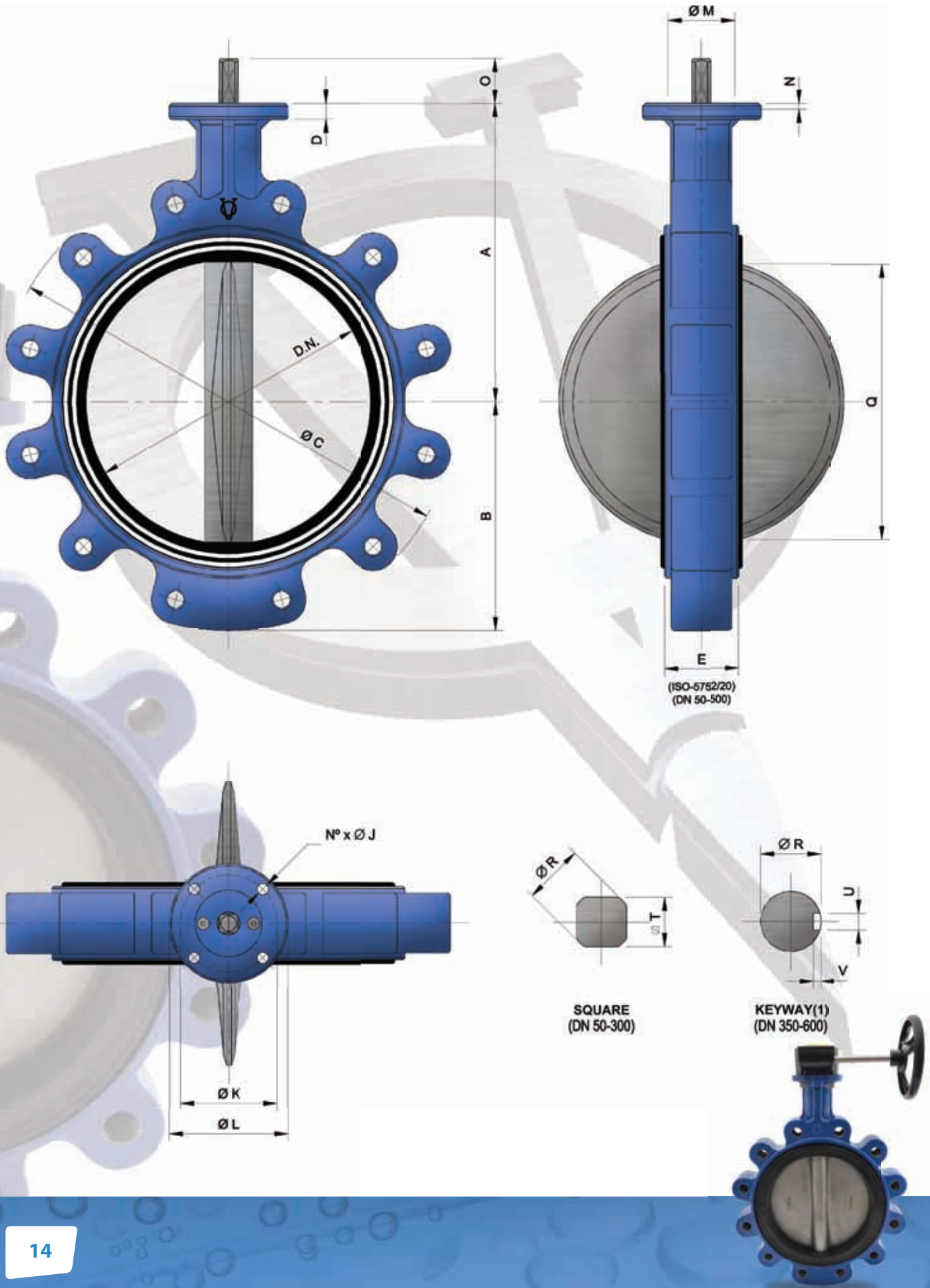



# Standard manufacture range

## 500 Series Lug Type

### Features

- ✓ Nominal diameters from 50 mm (2") to 600 mm (24").
- ✓ Assembly between flanges to DIN PN-10, PN-16 and ANSI 125/150. (for other drilling standards, please ask).
- ✓ Standard working pressure 16 bar (DN 50-300) and 10 bar (DN 350-600) for higher pressures, ask our Commercial Department.
- ✓ Temperature limits from -45°C to +200°C (depending on type of liners and coatings).
- ✓ As this is a design to be assembled with screws or studs threaded to the valve body, it must be taken into consideration that the pipe transfers compression and traction mechanical stresses. For this reason, the use of compensation joints or any other element absorbing the above mentioned mechanical effects must be foreseen.
- ✓ Perfect alignment with the pipe flanges thanks to its design.
- ✓ Enables to place other type of valves or devices in continuous position, eliminating thus accessories and gaining useful space.
- ✓ Its use enables repairs downstream of valve as this is not loose due to the lack of one flange, as the valve would remain secured to the flange upstream.
- ✓ Should the LUG type valve is occasionally used at the end of the line, the body cannot be cast iron due to the mechanical stress furthermore, the following pressures must not be exceeded:

- DN 50 through DN 150 ≤ 5,6 bar.
- DN 200 through DN 600 ≤ 3,5 bar.

- For higher nominal diameters, ask our Commercial Department.

- Once the repair has been made and before putting the line into operation under normal conditions, the pipe should be assembled again downstream or, at least, another flange so that the valve is assembled between two flanges.

**DIRECTION OF THE FLUID** →

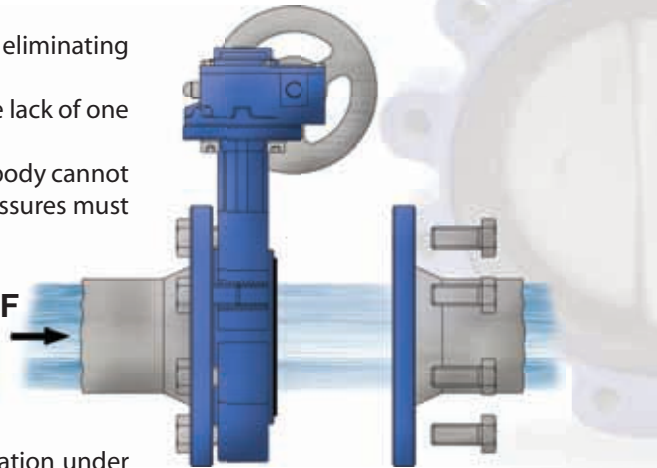

### DIMENSIONS

DN		BODY DIMENSIONS					ASSEMBLY FLANGE							SHAFT END					"Q"	WEIGHT (Kg)
mm	Inch	A	B	Ø C	D	E	ISO-5211/2	Nº	Ø J	Ø K	Ø L	Ø M <sub>(1)</sub>	N <sub>(1)</sub>	O	Ø R	Ø T	U	V		
50	2"	140	63	152	12	43	F-07	4	9	70	90	55	3	26	13.2	11			32	3.2
65	2½"	152	73	178	12	46	F-07	4	9	70	90	55	3	26	13.2	11			51	4.3
80	3"	159	81	200	12	46	F-07	4	9	70	90	55	3	26	13.2	11			69	6
100	4"	178	97	229	14	52	F-07	4	9	70	90	55	3	30	16.8	14			89	8
125	5"	191	112	254	14	56	F-07	4	9	70	90	55	3	30	16.8	14			115	9.8
150	6"	203	122	280	15	56	F-07	4	9	70	90	55	3	33	20.4	17			143	11.5
200	8"	245	149	343	15	60	F-07	4	9	70	90	55	3	33	20.4	17			194	18.3
250	10"	275	203	406	17	68	F-10	4	11	102	125	70	3	47	28	22			243	31.5
300	12"	315	241	483	17	78	F-10	4	11	102	125	70	3	47	28	22			293	48.3
350	14"	307	291	535	22	78	F-12	4	13	125	150	85	3	55	36		10	4.7	332	57.6
400	16"	342	325	597	24	102	F-14	4	17	140	175	100	4	65	42		12	4.9	382	93.1
450	18"	377	357	635	27	113	F-14	4	17	140	175	100	4	65	48		14	5.5	432	114.1
500	20"	425	381	715	27	126	F-14	4	17	140	175	100	4	65	48		14	5.5	478	158.3
600	24"	532	488	840	40	146	F-25	8	18	254	300	200	5	110	72		20	7.4	585	297

Dimensions in mm are orientative

VAMEIN DE ESPAÑA, S.A. reserves the right to modify dimensions with no previous advise.

(1): Central recess Ø M x N optional in DN 50-200.

# Manual actuators

## Lever

### PAI-01/02 (DN 50-200):

#### Features

- ✓ Injected aluminium casting.
- ✓ Stainless steel bolting.
- ✓ Complete integrated lever set for direct mounting on valve.
- ✓ Ideal for mounting in pipe-systems with heat-insulation.
- ✓ 6 regulating positions.
- ✓ Interchangeable plate for VAMEIN logo (Other logo-types upon request).
- ✓ Padlock blocking device.
- ✓ Possibility to fit limit switches for remote position indication.

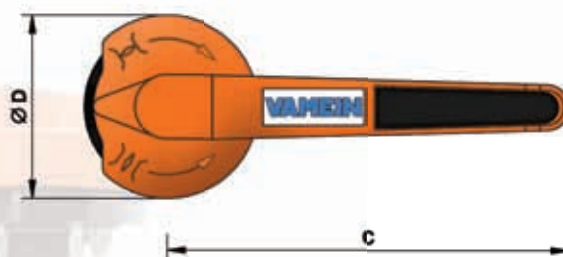
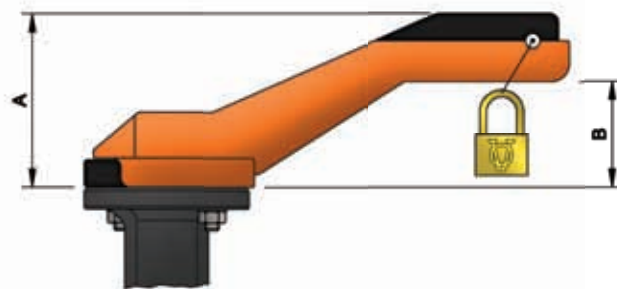

CODE	DN	A	B	C	Ø D	WEIGHT (Kg)
PAI01-11	50-80	95	58	220	100	0.7
PAI01-14	100	95	58	220	100	0.7
PAI02-14	125	95	58	320	100	0.8
PAI02-17	150-200	95	58	320	100	0.8

Dimensions in mm are orientative

### PA-1005 (DN 250-300):

#### Features

- ✓ Aluminium casting.
- ✓ 10 regulating positions.
- ✓ Possibility to fit limit switches for remote positioning indication.

*NOTE: For DN 250 and 300, and due to the great effort necessary to operate the levers, it is advisable to choose the gearbox as a manual actuator.*

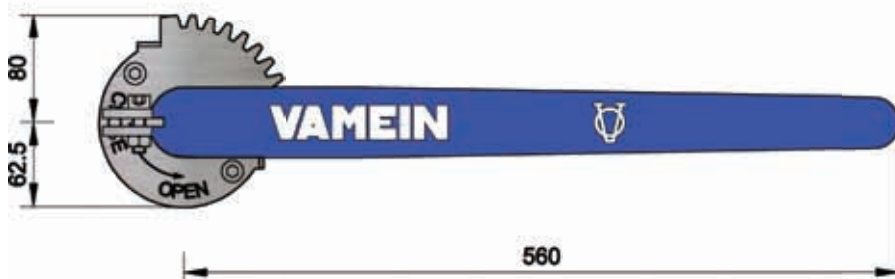

CODE	DN	WEIGHT (Kg)
PA1005-22	250-300	2,4

Dimensions in mm are orientative



# Manual actuators

## Gearbox

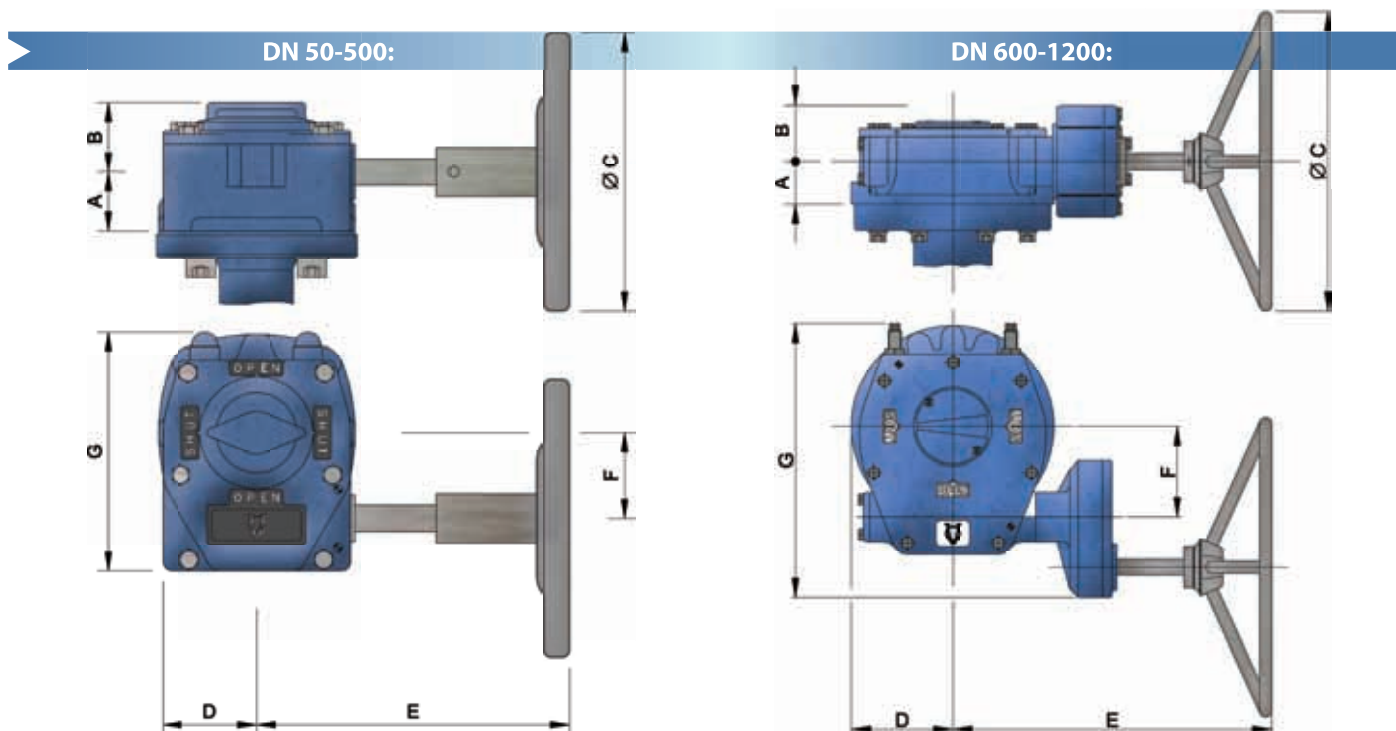

GEARBOX REFERENCE	A	B	Ø C	D	E	F	G	RATIO	TURNS AT 90°	WEIGHT (Kg)
RS DN 50-80	26.5	31.8	140	44	145,5	38.5	107,3	40:1	10	3,1
RS DN 100-125	26.5	31.8	140	44	145,5	38.5	107,3	40:1	10	3,1
RS DN 150-200	26.5	31.8	140	44	145,5	38.5	107,3	40:1	10	3,1
RS DN 250-300	28,6	34	250	51	212	52	130	37:1	9,25	5,2
RS DN 350	40,5	47	300	65	282	71	180	34:1	8,5	10,5
RS DN 400	42	50,5	300	77	270	86	226	38:1	9,5	16
RS DN 450-500	48	53.5	400	91	326	104,5	258	55:1	13,75	26
RS DN 600-800	55	100	500	142,5	447	130	402,5	208:1	52	49
RS DN 900-1000	59	100	600	185	500	182	482	312:1	79	75
RS DN 1050-1100	59	110	600	185	556	182	584	702:1	175	105
RS DN 1200	85	110	700	255	589	256	725	705:1	176	231

Dimensions in mm are orientative

### Features

- ✓ Construction: cast iron body, gear mechanism from steel.
- ✓ Precise close position which guarantees full tightness.
- ✓ Self-blocking mechanism.
- ✓ Mechanical stoppers enabling regulation..
- ✓ Lubricated for life.
- ✓ Visual position indicator.
- ✓ Protection class IP 67.
- ✓ Possibility of padlock device.
- ✓ Mounting of limit switches for remote position indication possible.
- ✓ Underwater-application and service possible (IP 68)

# Automatic actuators

A very important aspect of **VAMEIN** butterfly valves is, that they can easily equipped with any electric, pneumatic or hydraulic standardized actuator, directly fitted onto the top flange of the valve which is designed to DIN ISO 5211. Thus any exchange of manual actuators by automatic actuators without any modifications or without using additional elements to fit the chosen actuator is possible. This operation can perfectly be done on site, with the possibility of a subsequent automation of the installation without the need for expensive and problematic accessories or, in the worst case, the shut-off of process lines.

## Electric actuator Type VJ

### Features:

Specifically developed for 1/4 turn applications with rotation angles up to 270°. Wide range of operation torque values from 20 to 300 Nm with a huge basic equipment in its standard version.

- ✓ ATC – Automatic Temperature Control, ambient heater
- ✓ AVS – Automatic Voltage Sensing with only 2 voltage series: Series L 12-48V AC/DC, Series H 85 – 240V AC/DC
- ✓ ETL – Electronique Torque Limiter
- ✓ MO - Manual Emergency Operation

### Options:

- ✓ Housing and cover in aluminium or stainless steel.
- ✓ Electronic positioner 4-20 mA or 0-10 V
- ✓ BSR Emergency battery pack (equipped with rechargeable storage batteries).



## SELECTION AND DIMENSIONS OF ELECTRIC ACTUATORS TYPE VJ

Reference	DN Application	High	Width	Length	Operation Time (sec/90°)	Weight (Kg)
H/L 35	50-80	171	110	177	11/12	1.7
H/L 55	100-125	196	110	177	13/17	2.3
H/L 85	150	196	110	177	32/33	2.8
H/L 140/300	200-250	254	214	235	30-33/60-66	5.2

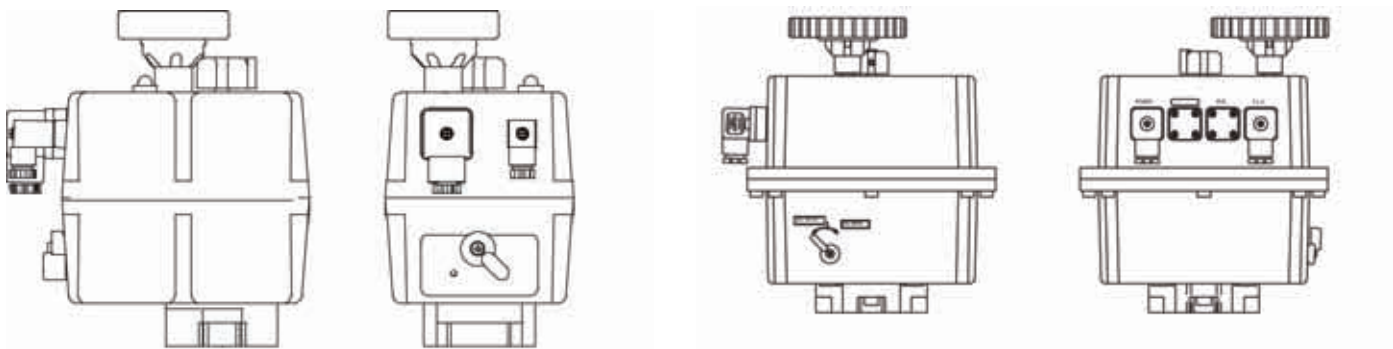

H/L 35/55/85

H/L 140/300



# Automatic actuators

## Electric actuator Type VAU

### Features:

- ✓ Cast iron and aluminium housing with strong superficial protection against corrosion. IP67
- ✓ Voltage range: 220/380/400/415/440/460 and 500 V AC (three phase) and 110-120/220-240V AC (single phase), 50 or 60 Hz
- ✓ 2 SPDT limit switches plus 2 adjustable torque limiter.
- ✓ Manual emergency override with clutch (electrical priority).
- ✓ Adjustable turn angle between 80° and 120° through mechanical stops.

### Options:

- ✓ Additional surface protection for specially corrosive atmospheres, intermediate position limit switches, electronic positioner 4-20 mA, class IP68, local control, Ex-proof protection.

### SELECTION AND DIMENSIONS ELECTRIC ACTUATORS TYPE VAU

Reference	DN Application	A	B	C	D	E	Operation Time (seg/90°)	Weight of Actuator (kg)
SG-03.3	50-80	207	166	215	195	87	8 A 22	8,3
SG-04.3	100-150	207	166	215	195	87	8 A 32	8,3
SG-05.1	200	265	153	98	170	302	8 A 32	18
SG-07.1	250-300	265	153	98	170	302	8 A 32	18
GS 80+SA-07.5.3	350-400	307	154	373	264	250	50 A 199	32,5
GS.100.3/Vz3.3+SA-07.5	450-500	321	220	470	264	250	75 A 600	52
GS.125.3/Vz4.3+SA-07.5	600-700	330	230	480	264	250	98 A 780	62
GS.160.3/Gz160.3+SA-07.5	750-800	313	337	653	264	250	74 A 829	110
GS.160.3/Gz160.3+SA-10.1	900-1000	323	337	655	282	256	72 A 814	110
GS.200.3/Gz200.3+SA-10.1	1050-1200	348	398	735	282	256	104 A 810	189

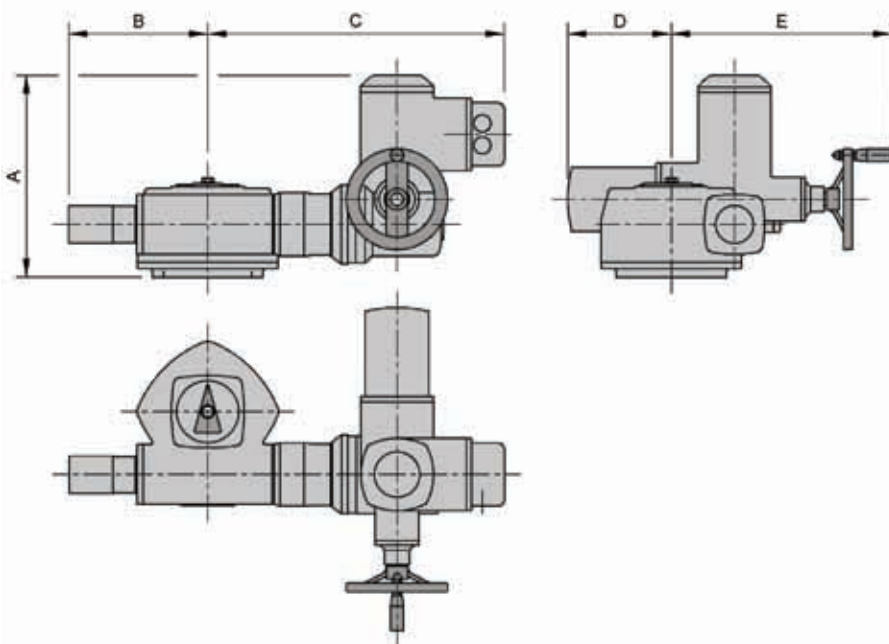

# Automatic actuators

## Pneumatic actuator Type VCH

### Features:

These pneumatic quarter-turn actuators stand out for their perfect performance, robustness and efficiency. Based on the proven rack and pinion principle, a high efficient and absolutely linear operation torque transmission is achieved.

Thanks to this technique a wide range of operation torque values has been reached: from 7,6 to 5.860 Nm for the double acting version and from 10 to 3.480 Nm in the spring return version, providing a constant air pressure supply of 6 bar.

The permanent lubrication, together with extreme machining tolerances of the internal surfaces (Ra 0.4 - 0.6 µm), and the excellent material of the gears with a very low friction coefficient (LAT LUB), guarantees a long service life close to one million operations.

Aiming at a perfect resistance to corrosion, there is a proper surface coating for each case of application and atmosphere: anodized aluminum, chemical nickel or PTFE-coated.

The actuators are suitable for a temperature range between -20°C and +80°C in normal service (other temperature ranges upon request).

The mounting on valves is very easy because of the connection flange according to ISO 5211 / DIN 3337.

Both, the connections for air supply and the upper interface for the mounting of devices, as solenoid valves, limit switch boxes or positioners, comply with NAMUR recommendations.



### Options:

- ✓ Regulating Limit Switch Box (electromechanical, inductive, magnetic or pneumatic) with NAMUR (VDI/VDE-3845) standard connection.
- ✓ Inductive or magnetic detectors.
- ✓ Solenoid valves (3/5 ways), also Ex-proof.
- ✓ Pneumatic (3-15 psi) and electro-pneumatic (4-20 mA) positioners.
- ✓ Manual emergency override with declutching gearbox.

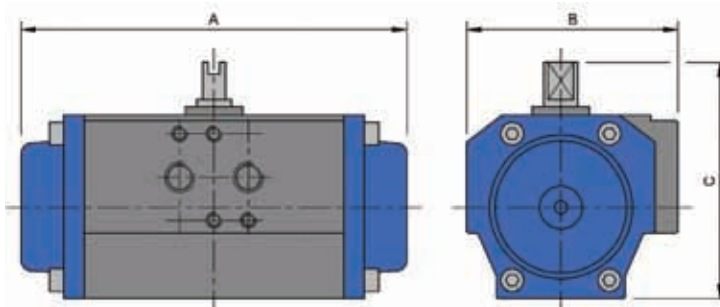

## SELECTION AND DIMENSIONS OF PNEUMATIC ACTUATORS TYPE VCH

Reference D.E. / S.E.	Dimensions (mm)			Weight (Kg)		Double Acting		Spring Return	
	A	B	C	D.E.	S.E.	Ref.	DN Application	Ref.	DN Application
CH063/CH063SR	156	86	103	1,6	1,8	CH063	50-65-80	CH063SR	-
CH075/CH075SR	210	94	120	2,9	3,4	CH075	100-125	CH075SR	50-65-80
CH100/CH100SR	280	120	145	5,8	6,8	CH100	150-200	CH100SR	100-125
CH125/CH125SR	362	141	185	11,9	14,2	CH125	250-300	CH125SR	150-200
CH160/CH160SR	462	176	246	20,5	25	CH160	-	CH160SR	250-300
CH200/CH200SR	575	220	290	43	53	CH200	350-400	CH200SR	-
CH270/CH270SR	685	352	382	94	113	CH270	450-500	CH270SR	350-400
CH330/CH330SR	850	400	464	105	145	CH330	600-700	CH330SR	450-600



# Seat liners

## Design

They are specially designed by **VAMEIN DE ESPAÑA, S.A.** to allow a perfect fit with the valve's body and making it completely watertight. Their O-RINGS allow a perfect seal with the flanges without requiring any additional joints.

For the valve life and perfect working it is imperative that the right seat material is chosen for the line conditions, i.e., temperature and chemical composition of fluid.

**VAMEIN DE ESPAÑA, S.A.** Technical Department is prepared to help you choose the right kind of seat. Do not hesitate to ask about the particular conditions of the fluid to be used.

## Detailed ways on fitting the seat to the body

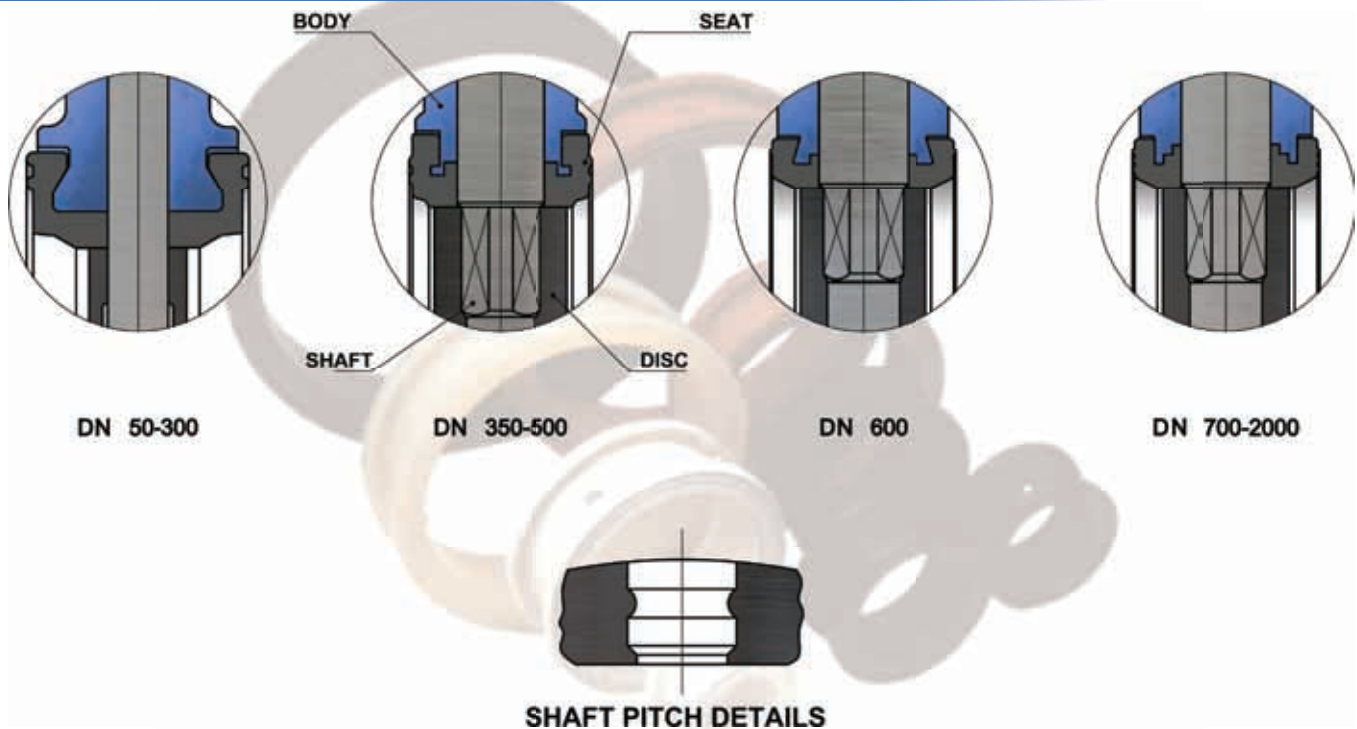

## Codes and temperatures of the most usual liners

MATERIAL	VAMEIN CODE	COMERCIAL CODE	° C MINIMUN TEMPERATURE	° C MAXIMUN TEMPERATURE
EPDM	E	EPDM	-15	100 (110)
HT-EPDM	EC	EPDM HT	-15	120 (130)
BUNA-N	N	NBR	-15	100 (115)
HYPALON	H	CSM	-15	105 (115)
VITON	V	FKM	-20	180 (200)
SILICONE	S	VMQ	-40	180 (200)

**N.B.:** There are two possible maximum temperatures, depending if the temperature applied is constant or intermittent. Those shown in brackets refer to the intermittent temperature.

It is to be taken into account that the more the working temperature approaches the limit temperature of the liner, the more premature ageing will take place and its original qualities reduced more quickly. Temperatures just as an information.

# Hydraulic features

## Kv (m<sup>3</sup>/hour) Values

Values shown in the following table are in m<sup>3</sup>/hour in order to make the pressure drop calculation easier.

DN VALVE		OPENING ANGLE							
mm	Inches	20°	30°	40°	50°	60°	70°	80°	90°
50	2"	7	16	26	43	69	110	170	190
65	2½"	9	22	38	60	95	155	250	280
80	3"	14	33	57	95	150	240	370	430
100	4"	24	54	95	155	240	400	620	710
125	5"	38	86	155	240	390	640	950	1.100
150	6"	52	120	220	345	550	950	1.400	1.600
200	8"	95	220	345	600	950	1.600	2.400	2.800
250	10"	155	345	610	950	1.600	2.600	4.000	4.700
300	12"	220	510	860	1.500	2.300	3.800	5.900	6.900
350	14"	290	660	1.200	1.900	2.900	4.800	7.800	8.600
400	16"	380	860	1.600	2.400	3.900	6.400	9.500	11.200
450	18"	490	1.100	2.000	3.100	5.000	8.300	12.900	15.500
500	20"	610	1.400	2.500	4.000	6.200	10.300	15.500	19.000
600	24"	860	2.000	3.400	5.500	8.600	14.700	22.400	25.900
650	26"	980	2.300	4.000	6.100	10.400	16.650	25.850	31.500
700	28"	1.100	2.600	4.600	6.700	12.200	18.600	29.300	37.100
750	30"	1.300	3.100	5.200	8.500	13.800	22.400	34.500	40.500
800	32"	1.800	3.600	6.600	9.700	16.600	28.300	43.200	52.300
900	36"	2.200	4.500	7.800	12.900	19.800	32.800	51.700	60.300
1.000	40"	3.100	5.300	8.700	16.000	24.100	42.200	62.100	78.400
1.050	42"	3.400	5.900	9.600	17.700	26.600	46.600	68.400	86.200
1.100	44"	3.800	6.500	10.600	19.500	29.300	51.300	75.100	95.100
1.200	48"	4.500	7.800	12.700	23.300	35.200	61.500	90.700	114.400

Kv (Cv) Flow coefficient value definition =Water flow value in l/ minute at 20° C (US gallons/minute at 60 ° F), which passing through a valve creates a pressure drop of 1 Kg/cm2. (1 p.s.i.)

**Kv – Cv Ratio:**  
**Cv (US Gallons / minute) = 1,155 • Kv (l/minute)**

**N.B.:** This ratio is only valid for the above mentioned units.





# Torque table

NOMINAL DIAMETER		WORK PRESSURE	10 bar	16 bar	150 p.s.i.	225 p.s.i.
mm	Inches	UNITS	N•m	N•m	Lbs x Inch.	Lbs x Inch.
50	2"	TORQUES	15	15	133	133
65	2 ½"		20	20	177	177
80	3"		25	25	221	221
100	4"		40	40	354	354
125	5"		50	50	443	443
150	6"		60	60	531	531
200	8"		160	160	1.416	1.416
250	10"		250	250	2.213	2.213
300	12"		300	300	2.655	2.655
350	14"		900	1.350	7.965	11.948
400	16"		1.200	1.800	10.620	15.930
450	18"		1.650	2.400	14.603	21.240
500	20"		2.300	3.500	20.355	30.975
600	24"		4.100	6.150	36.285	54.428
650	26"		4800	7200	42480	63720
700	28"		5.500	8.250	48.675	73.013
750	30"		6.500	9.500	57.525	84.075
800	32"		8.100	12.150	71.685	107.528
900	36"		10.000	15.000	88.500	132.750
1.000	40"		13.500	20.000	119.475	177.000
1.050	42"	14.200	21.300	188.505	125.670	
1.100	44"	15.000	22.000	132.750	194.700	
1.200	48"	16.500	24.500	146.025	216.825	

REMARK: Torques listed in the above table are a guideline and they have been calculated for a constant pressure and working conditions and valid for "VAMEIN" butterfly valves with PTFE liners and water at ambient temperature (20° C approx.) at 10 bar pressure.

As the figures we presented in the above table were obtained from tests made on static benches, it is necessary to take into consideration the dynamic conditions of the fluid for every specific line (velocity, flow, cavitation, hydraulic factors, etc), specially for the hydrodynamic stress caused by the flow on the valve disc.

The "VAMEIN" butterfly valve is designed to work with fluids, which act like lubricants. For air or gas service, torques are considerably higher, at least 35 %. In this case, please contact our Technical Department to analyze the situation and get the best advice.

Safety factors are included in these torque values.



# Bolting list

## DIN PN-10 STANDARD

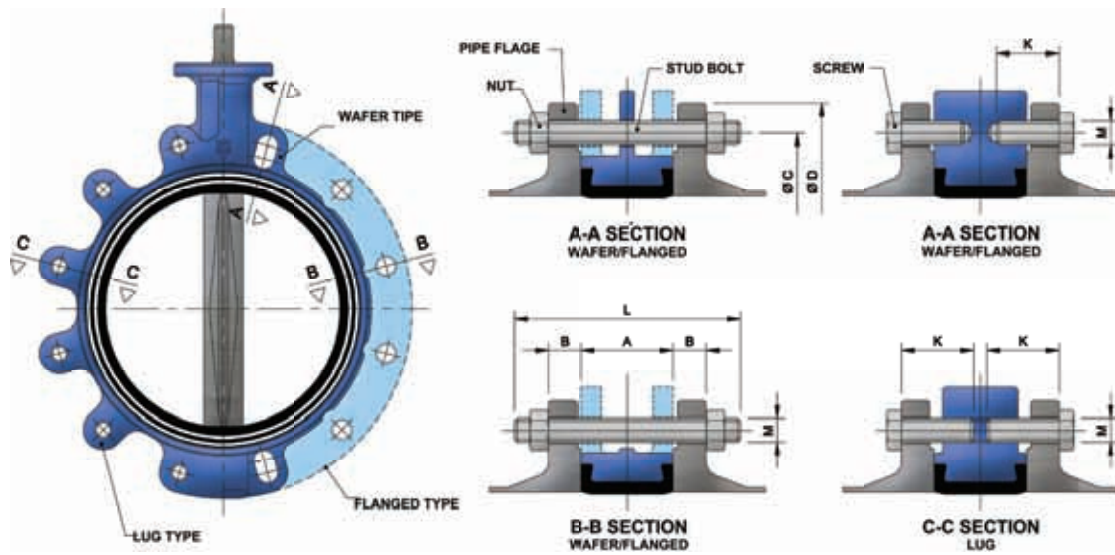

### DIN PN-10 STANDARD

VALVE		FLANGES (DIN-2632)					NECESSARY BOLTS FOR WAFFER AND FLANGED TYPE						BOLTS FOR LUG TYPE				
DN		FACE TO FACE	THICKNESS	BOLT CENTRE	QUANTITY	Ø EXTERNAL	STUD BOLTS			NUTS		SCREWS			SCREWS		
							LENGTH	THREAD	QUANTITY	THREAD	QUANTITY	LENGTH	THREAD	QUANTITY	LENGTH	THREAD	QUANTITY
mm	Inch.	A	B	Ø C	Nº	Ø D	L	M	Nº	M	Nº	L	M	Nº	L	M	Nº
50	2"	43	18	125	4	165	120	M-16	4	M-16	8				35	M-16	8
65	2½"	46	18	145	4	185	125	M-16	4	M-16	8				35	M-16	8
80	3"	46	20	160	8	200	130	M-16	8	M-16	16				40	M-16	16
100	4"	52	20	180	8	220	135	M-16	8	M-16	16				40	M-16	16
125	5"	56	22	210	8	250	140	M-16	8	M-16	16				45	M-16	16
150	6"	56	22	240	8	285	150	M-20	8	M-20	16				45	M-20	16
200	8"	60	24	295	8	340	160	M-20	8	M-20	16				50	M-20	16
250	10"	68	26	350	12	395	170	M-20	12	M-20	24				55	M-20	24
300	12"	78	26	400	12	445	180	M-20	12	M-20	24				60	M-20	24
350	14"	78	26	460	16	505	180	M-20	16	M-20	32				60	M-20	32
400	16"	102	26	515	16	565	215	M-24	16	M-24	32				70	M-24	32
*450	18"	113	28	565	20	615	230	M-24	20	M-24	40				80	M-24	40
500	20"	126	28	620	20	670	240	M-24	20	M-24	40				85	M-24	40
600	24"	146	28	725	20	780	270	M-27	16	M-27	32	75	M-27	8	75	M-27	8
700	28"	175	30	840	24	895	305	M-27	20	M-27	40	80	M-27	8	95	M-27	32
750	30"	176	-	-	-	-	-	-	-	-	-	-	-	-			
800	32"	215	32	950	24	1015	355	M-30	20	M-30	40	90	M-30	8			
900	36"	246	34	1050	28	1115	390	M-30	24	M-30	48	90	M-30	8			
1000	40"	280	34	1160	28	1230	430	M-33	24	M-33	48	90	M-33	8			
1050	42"	280	-	-	-	-	-	-	-	-	-	-	-	-			
1100	44"	280	-	-	-	-	-	-	-	-	-	-	-	-			
1200	48"	360	38	1380	32	1455	525	M-36	28	M-36	56	95	M-36	8			

For DN>1200, please consult.

(\*): As per B.S. 4504 PN-10.



# Bolting list

## DIN PN-16 STANDARD

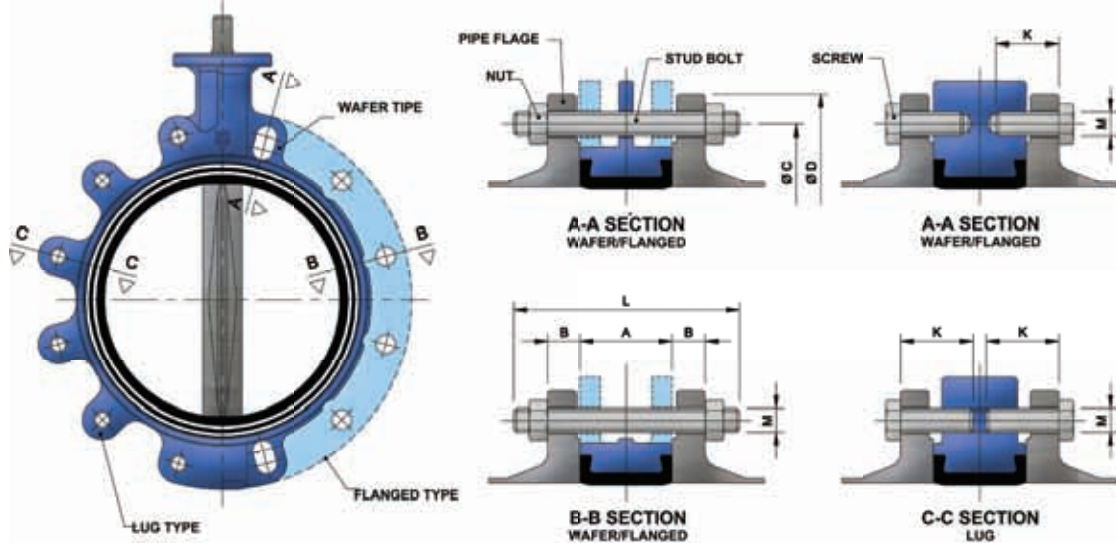

DIN PN-16 STANDARD																	
VALVE		FLANGES (DIN-2633)					NECESSARY BOLTS FOR WAFFER AND FLANGED TYPE						BOLTS FOR LUG TYPE				
DN	FACE TO FACE	THICKNESS	BOLT CENTRE	QUANTITY	Ø EXTERNAL	STUD BOLTS			NUTS		SCREWS			SCREWS			
						LENGTH	THREAD	QUANTITY	THREAD	QUANTITY	LENGTH	THREAD	QUANTITY	LENGTH	THREAD	QUANTITY	
mm	Inch.	A	B	Ø C	Nº	Ø D	L	M	Nº	M	Nº	L	M	Nº	L	M	Nº
50	2"	43	18	125	4	165	120	M-16	4	M-16	8				35	M-16	8
65	2½"	46	18	145	4	185	125	M-16	4	M-16	8				35	M-16	8
80	3"	46	20	160	8	200	130	M-16	8	M-16	16				40	M-16	16
100	4"	52	20	180	8	220	135	M-16	8	M-16	16				40	M-16	16
125	5"	56	22	210	8	250	140	M-16	8	M-16	16				45	M-16	16
150	6"	56	22	240	8	285	150	M-20	8	M-20	16				45	M-20	16
200	8"	60	24	295	12	340	160	M-20	12	M-20	24				50	M-20	24
250	10"	68	26	355	12	405	180	M-24	12	M-24	24				55	M-24	24
300	12"	78	28	410	12	460	195	M-24	12	M-24	24				65	M-24	24
350	14"	78	30	470	16	520	195	M-24	16	M-24	32				65	M-24	32
400	16"	102	32	525	16	580	235	M-27	16	M-27	32				80	M-27	32
*450	18"	113	34	585	20	640	250	M-27	20	M-27	40				85	M-27	40
500	20"	126	34	650	20	715	270	M-30	20	M-30	40				95	M-30	40
600	24"	146	36	770	20	840	300	M-33	16	M-33	32	75	M-33	8	85 100	M-33 M-33	8 32
700	28"	175	36	840	24	910	325	M-33	20	M-33	40	80	M-33	8			
750	30"	176	-	-	-	-	-	-	-	-	-	-	-	-			
800	32"	215	38	950	24	1025	380	M-36	20	M-36	40	90	M-36	8			
900	36"	246	40	1050	28	1125	415	M-36	24	M-36	48	90	M-36	8			
1000	40"	280	42	1170	28	1255	460	M-39	24	M-39	48	90	M-39	8			
1050	42"	280	-	-	-	-	-	-	-	-	-	-	-	-			
1100	44"	280	-	-	-	-	-	-	-	-	-	-	-	-			
1200	48"	360	48	1390	32	1485	565	M-45	28	M-45	56	105	M-45	8			

For DN>1200, please consult

(\*): As per B.S. 4504 PN-16.

# Bolting list

## ANSI B16.5 Class 150 Lbs & ASME B16.47 Class 150 Lbs A-Series

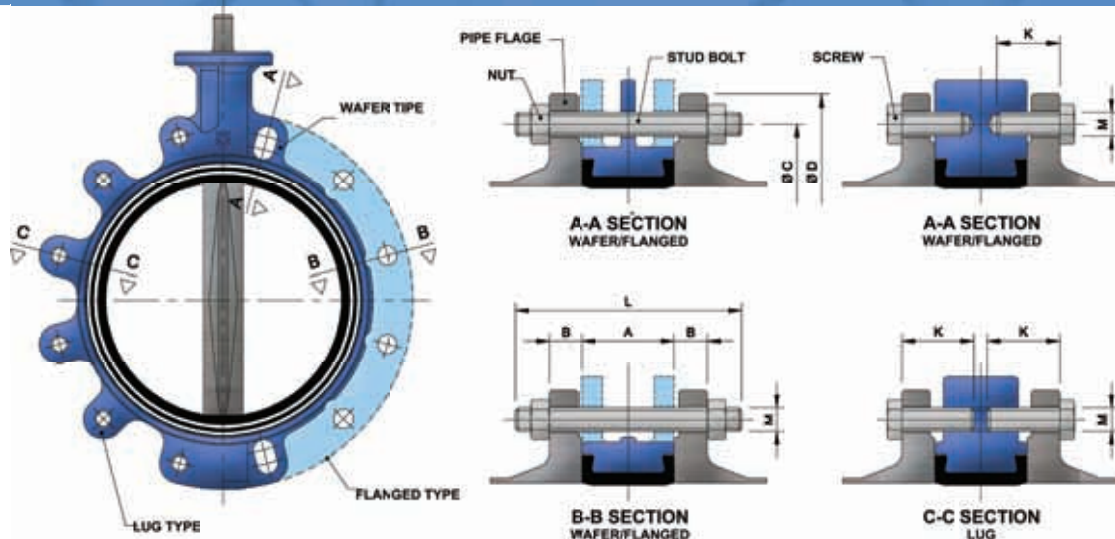

### ANSI 150 Lbs. STANDARD

VALVE		FLANGES					NECESSARY BOLTS FOR WAFER AND FLANGED TYPE									BOLTS FOR LUG TYPE		
DN	FACE TO FACE	THICKNESS	BOLT CENTRE	QUANTITY	Ø EXTERNAL	STUD BOLTS			NUTS		SCREWS			SCREWS				
						LENGTH	THREAD	QUANTITY	THREAD	QUANTITY	LENGTH	THREAD	QUANTITY	LENGTH	THREAD	QUANTITY		
mm	Inch	A	B	Ø C	Nº	Ø D	L	M	Nº	M	Nº	L	M	Nº	L	M	Nº	
50	2"	43	19.1	120.6	4	152.4	120	5/8"UNC	4	5/8"UNC	8				35	5/8"UNC	8	
65	2½"	46	22.2	139.7	4	177.8	130	5/8"UNC	4	5/8"UNC	8				40	5/8"UNC	8	
80	3"	46	23.8	152.4	4	190.5	135	5/8"UNC	4	5/8"UNC	8				40	5/8"UNC	8	
100	4"	52	23.8	190.5	8	228.6	140	5/8"UNC	8	5/8"UNC	16				45	5/8"UNC	16	
125	5"	56	23.8	215.9	8	254	155	3/4"UNC	8	3/4"UNC	16				45	3/4"UNC	16	
150	6"	56	25.4	241.3	8	279.4	155	3/4"UNC	8	3/4"UNC	16				45	3/4"UNC	16	
200	8"	60	28.6	298.4	8	342.9	165	3/4"UNC	8	3/4"UNC	16				50	3/4"UNC	16	
250	10"	68	30.2	361.9	12	406.4	185	7/8"UNC	12	7/8"UNC	24				60	7/8"UNC	24	
300	12"	78	31.7	431.8	12	482.6	200	7/8"UNC	12	7/8"UNC	24				65	7/8"UNC	24	
350	14"	78	34.9	476.2	12	533.4	215	1"UNC	12	1"UNC	24				70	1"UNC	24	
400	16"	102	36.5	539.7	16	596.9	245	1"UNC	16	1"UNC	32				85	1"UNC	32	
450	18"	113	39.7	577.8	16	635	265	1 ½"UN	16	1 ½"UN	32				90	1 ½"UN	32	
500	20"	126	42.9	635	20	698.5	285	1 ½"UN	20	1 ½"UN	40				100	1 ½"UN	40	
600	24"	146	47.6	749.3	20	812.8	305	1 ¼"UN	16	1 ¼"UN	32	90	1 ¼"UN	8	90	1 ¼"UN	8	
															110	1 ¼"UN	32	

### ASME B16.47 CLASE-150 Lbs STANDARD A-SERIES

650	26"	175	68	806.45	24	869.9	380	1 ¼"UN	20	1 ¼"UN	40	110	1 ¼"UN	8			
700	28"	175	71.4	863.6	28	927.1	390	1 ¼"UN	24	1 ¼"UN	48	115	1 ¼"UN	8			
750	30"	176	74.6	914.4	28	984.2	400	1 ¼"UN	24	1 ¼"UN	48	120	1 ¼"UN	8			
800	32"	215	81	977.9	28	1060.4	460	1 ½"UN	24	1 ½"UN	48	135	1 ½"UN	8			
900	36"	246	90.5	1085.8	32	1168.4	510	1 ½"UN	28	1 ½"UN	56	140	1 ½"UN	8			
1000	40"	280	90.5	1200.1	36	1289	545	1 ½"UN	32	1 ½"UN	64	145	1 ½"UN	8			
1050	42"	280	96.8	1257.3	36	1346.2	570	1 ½"UN	32	1 ½"UN	64	155	1 ½"UN	8			
1100	44"	280	101.6	1314.5	40	1403.4	580	1 ½"UN	36	1 ½"UN	72	160	1 ½"UN	8			
1200	48"	360	108	1422.4	44	1511.3	670	1 ½"UN	40	1 ½"UN	80	165	1 ½"UN	8			

For DN >1200, please consult

# Key Figures

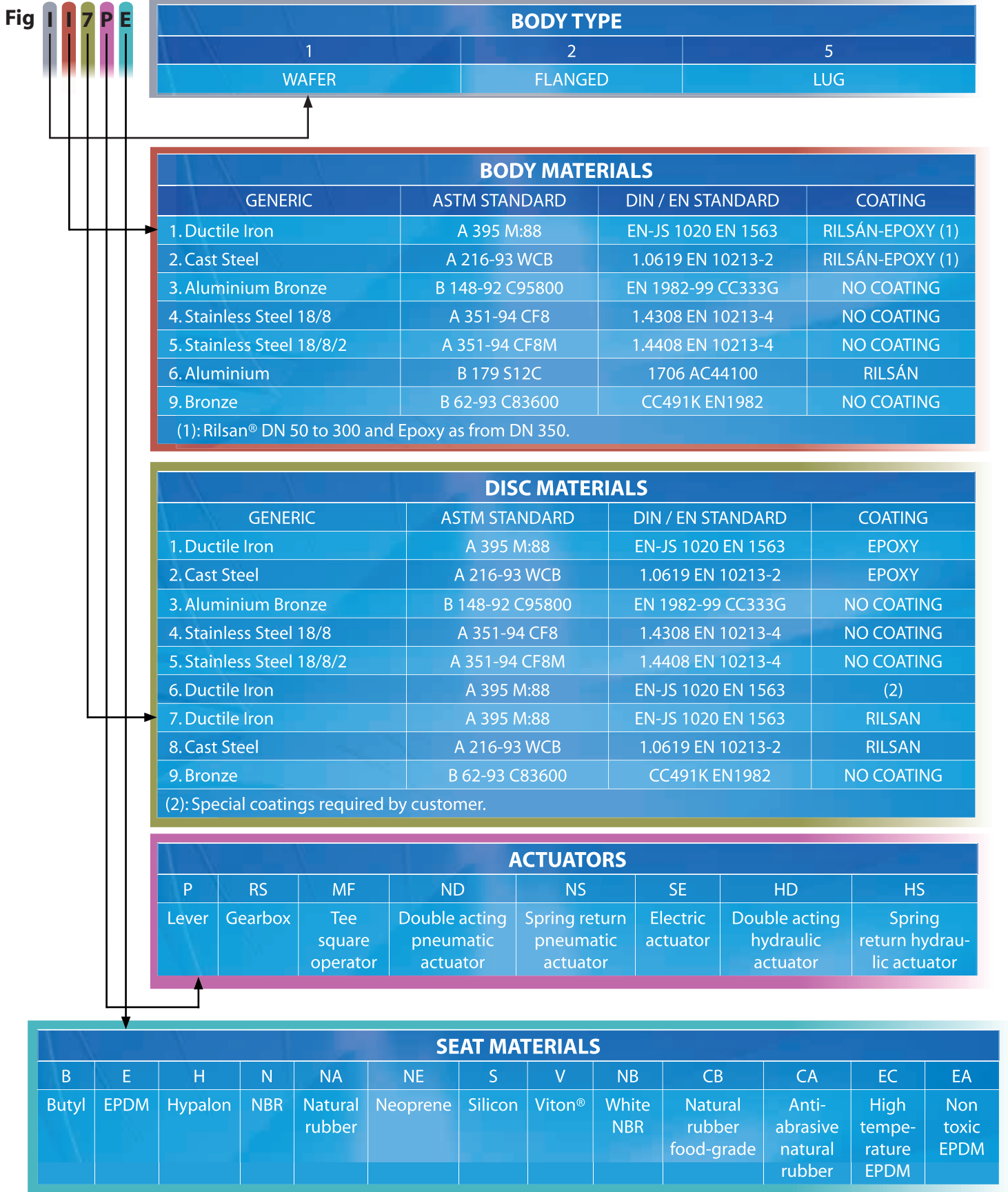

NOTE: For materials, coatings or actuators other than those listed above, please contact our Technical Department





COMMERCIAL CATALOGUE - EDITION 02 - JUNE 2010

Authorised Distributor:



**NATIONWIDE  
OIL & GAS**

46, Jalan SS 22/21, Damansara Jaya,  
47400 Petaling Jaya, Selangor Darul Ehsan, Malaysia.

Email: [nog@nog.com.my](mailto:nog@nog.com.my)

Web access: <http://www.nog.com.my>

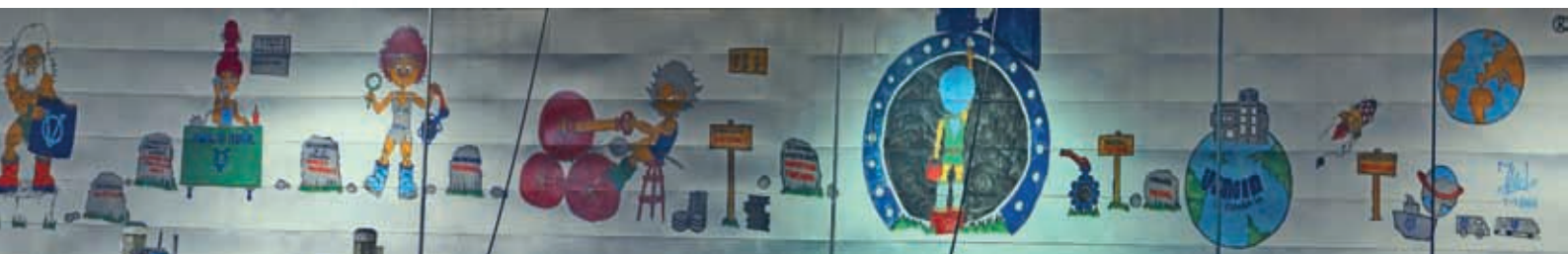

Design: [www.intelligent-studios.com](http://www.intelligent-studios.com)  
photograph: Maxi Conesa