

# ProtEX-MAX PD8-6080/PD8-6081 Modbus® Scanners

## Data Sheet



- CSA Certified Explosion-Proof Modbus® Scanners
- Modbus® RS-485 RTU Scanner as Master, Slave, or Snooper
- Dual Analog Inputs (0-20 mA, 4-20 mA, 0-5 V, 1-5 V, and  $\pm 10$  V)
- On-Board USB & RS-485 Serial Communication Standard
- Decimal or Feet & Inches (with Eighths & Sixteenths) Display Options
- Poll and Display up to 16 Process Variables
- Add, Diff, Avg, Multi, Div, Min, Max, Weighted Avg, Ratio, Concentration, & More
- Dual-Line 6-Digit Display, 0.6" (15 mm) & 0.46" (12 mm)
- SafeTouch Through-Glass Button Programming
- Display Mountable at 0°, 90°, 180°, & 270°
- Isolated 24 VDC @ 25 mA Transmitter Power Supply
- 4 Relays with Interlocking Capability + Isolated 4-20 mA Output Option
- Password Protection
- Free PC-Based, On-Board, ScanView USB Programming Software
- SunBright Display Standard Feature; Great for Outdoor Applications
- Operating Temperature Range: -55 to 65°C (-67 to 149°F)
- CSA Certified as Explosion-Proof / Dust-Ignition-Proof / Flame-Proof
- Input Power Options: 85-265 VAC / 90-265 VDC or 12-24 VDC / 12-24 VAC
- Multi-Pump Alternation Control
- 32-Point, Square Root, or Exponential Linearization
- Flanges for Wall or Pipe Mounting
- Explosion-Proof Aluminum or Stainless Steel NEMA 4X / IP68 Enclosures
- Four 3/4" NPT Threaded Conduit Openings
- Pipe Mounting Kits
- Stainless Steel Tag Available
- 3-Year Warranty

# The Complete **ProtEX™** Series

MAX



PD8-154  
**4-Point Alarm  
Annunciator**



PD8-6100  
**Strain Gauge Meter**



PD8-158  
**8-Point Alarm  
Annunciator**



PD8-6200  
**Analog Input  
Flow Rate/Totalizer**



PD8-765  
**Process &  
Temperature Meter**



PD8-6210  
**Analog Input Batch  
Controller**



PD8-6000  
**Process Meter**



PD8-6262  
**Analog Dual-Input  
Flow Rate/Totalizer**



PD8-6001  
**Feet & Inches  
Level Meter**



PD8-6300  
**Pulse Input  
Flow Rate/Totalizer**



PD8-6060  
**Dual-Input  
Process Meter**



PD8-6310  
**Pulse Input  
Batch Controller**



PD8-6080  
**Modbus® Scanner  
with Dual Analog Input**



PD8-6363  
**Pulse Dual-Input  
Flow Rate/Totalizer**



PD8-6081  
**Feet & Inches  
Modbus® Scanner**



PD8-7000  
**Temperature Meter**

Go to [PREDIG.COM](http://PREDIG.COM) for details on the entire ProtEX-MAX Series Meters



PD8-6081 Shown

## TAKE ADVANTAGE OF YOUR MODBUS ENABLED TRANSMITTERS

By using the Modbus signal from your existing multivariable transmitters, you will open up a whole new dimension of display possibilities. Paired with a new Precision Digital Modbus Scanner, you can display multiple variables including level, interface level, density, temperature, and more. The ProtEX-MAX PD8-6080/81 Modbus Scanners are multi-purpose, easy-to-use scanners that can be programmed as Modbus RTU Masters, Slaves, or Snoopers. They are capable of scanning up to 16 process variables (PVs), which make them ideal for multiple tank level monitoring and control. Plus, they combine two independently programmed analog inputs with powerful math functions. Various math functions that may be applied to the inputs and PVs include addition, difference, average, multiplication, division, ratio, and more.

## KEY FEATURES

The ProtEX-MAX PD8-6080/81 can be programmed as a Modbus RTU Master, Slave, or Snooper. Its Modbus communications capabilities, two process input channels, and math functions make it unique, while still maintaining the great features and quality of the ProtEX-MAX family.

### Modbus RTU Serial Communications

As a Master, the ProtEX-MAX PD8-6080/81 reads up to 16 slave devices, scales the data from each, and displays each on an alternating display. In Master mode it is capable of polling up to 16 process variables (PVs) and can display each PV (PV1-PV16) alternately on the top and/or bottom display.

In Snooper mode, the PD8-6080/81 is able to read any of the variables being polled by the master by listening to the bus traffic. It picks up specific register or registers being polled by a master device from a specific slave device and processes the data being read.

As a Slave, the PD8-6080/81 is controlled by a master device. The data sent to it by the master is scaled, displayed, and used to operate the internal relays and 4-20 mA output.

## SafeTouch Button Programming

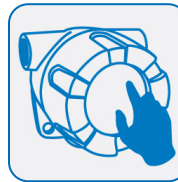

The ProtEX-MAX is equipped with four sensors that operate as through-glass buttons so that it can be programmed and operated without removing the cover (and exposing the electronics) in a hazardous area. The SafeTouch buttons are configured by default to duplicate the function of the front panel mechanical pushbuttons associated with the integrated meter.

## Standard SunBright LED Display

The ProtEX-MAX's SunBright display features extraordinarily bright LEDs. They are perfect for indoor and outdoor applications where visibility may be impaired by smoke, fog, dust, or distance or even in direct sunlight.

## Free USB Programming Software & Cable

The ProtEX-MAX comes preloaded with free ScanView programming software that connects and installs directly to your PC with a standard USB cable, also provided free with each instrument. This eliminates the need to insert CDs, install drivers, or download software from the internet. The software will allow you to configure, monitor, and datalog a ProtEX-MAX PD8-6080 using your PC. Just simply connect the meter to your PC with the USB cable and within minutes you will be programming it.

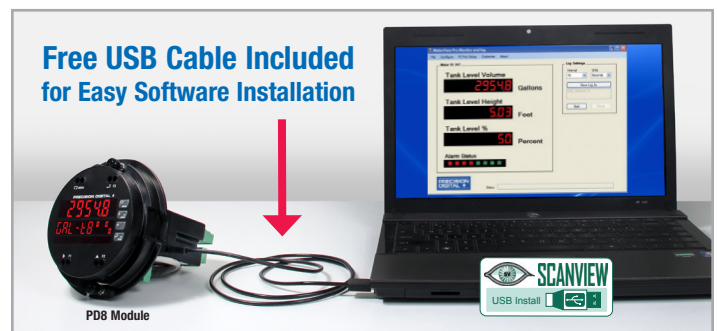

### Modbus Application Capabilities

The PD6080 & PD6081 scanners can communicate with any Modbus device using the ever-popular Modbus communications protocol. Take advantage of the Modbus capabilities in the level and flow transmitters you already have by using Master Mode to read more data, more accurately. Possible applications include:

- Use Master Mode to scan the top level, interface level, and temperature from Modbus multivariable level transmitters.
- Use Master Mode to display the flow rate, tag, and units, for multiple Modbus-enabled flow meters.
- Use Snooper Mode to add a tank side indicator at eye-level for a Modbus level transmitter being polled by a master in the control room.
- Use Snooper Mode to add additional remote displays to a network with a Modbus scanner acting as the master, and display the data at all operator locations.
- Use Slave Mode to display data sent to the scanner by a Modbus master in the control room.

These are just a few capabilities of using the PD6080 & PD6081 Modbus Scanners in a Modbus process network.

### Powerful Math Functions

The PD8-6080/81 uses up to 16 process variables in a variety of powerful math functions designed for process applications. Programmable Adder (P) and Factor (F) constants allow each formula to be customized as needed for a specific application. The Math Channels (C1-C4) may be displayed in many useful combinations. Most math functions may be applied to all PVs: for example, it is possible to add up to 16 PVs and calculate the total volume of all the tanks in a field. The Math2 function allows for further calculations on the results of other math channels (e.g. C4= C2/C1).

Name	Function	Setting
Addition	$C1=(PV1+PV2+P)*F$	5u0r
Difference	$C1=(PV1-PV2+P)*F$	d iF
Absolute Difference	$C1=((Abs(PV1- PV2)+P)*F$	d iFRb5
Average	$C1=(((PV1+PV2)/2)+P)*F$	RuG
Multiplication	$C1=((PV1*PV2)+P)*F$	0r0Lb i
Division	$C1=((PV1/PV2)+P)*F$	d u idE
Maximum PV	Maximum value of all selected PVs	X i-Pu
Minimum PV	Minimum value of all selected PVs	L o-Pu
Draw	$C1=((PV1/PV2)-1)*F$	d rRuJ
Weighted Average	$C1=((PV2-PV1)*F)+PV1$	uJ RuG
Ratio	$C1=(PV1/PV2)*F$	rRb io
Concentration	$C1=(PV1/(PV1+PV2))*F$	L oncEn
Resultant Math Channel	Math on all other math channels	0rRb hZ
Addition	$C3=(C1+C2+P)*F$	5u0r
Difference	$C4=(C1-C2+P)*F$	d iF
Absolute Difference	$C3=((Abs(C1- C2)+P)*F$	d iFRb5
Average	$C4=(((C1+C2)/2)+P)*F$	RuG
Multiplication	$C3=(((C1*C2)+P)*F$	0r0Lb i
Division	$C4=((C1/C2)+P)*F$	d u idE

Note: The F constant can be any value from 0.00001 to 999999. If the value is less than 1, it will have the same effect as a divider. For example, the average could also be derived by using  $(A+B)*F$ , where  $F = 0.500$ .

### Customizable Displays

The ProtEX-MAX has two red LED displays, an Upper display 0.60" (15 mm) high, and a Lower display 0.46" (12 mm) high. Each display is a full 6 digits (-99999 to 999999). The display assignment is programmable, allowing for various one line or two line PV configurations.



Alternating Tag and Units on the Bottom Display for Each PV



Displaying Two PVs

### Custom Tag and Units for Each PV

Each process variable has an independently programmable tag and unit name. The tag must display on the line opposite the PV or alternate with the PV during scanning. The unit may be configured to display similarly. The tag and unit may be programmed as any six-digit alphanumeric value.

### Automatic or Manual Scanning

The scanner may automatically or manually cycle through the PVs. The scanner can be programmed to display each PV for 1 to 99.9 seconds. The NEXT and PREV buttons can be used to manually scan to the next or previous PV display. The SCAN button will pause and resume automatic scanning.

### Function Keys

There are three front panel function keys, and a standard external digital input, which can be used as an external function "key" (F4). The external input is located on the rear signal connector (ground to trigger). The keys and external input trigger certain programmed events (i.e. acknowledge alarms, reset max and/or min, disable/enable output relays, and much more), provide direct menu access points, and more.

### On-Board Digital Input

The PD8-6080/81 includes a digital input as a standard feature. This digital input can operate with the interlock relays feature, force relays on from a signal from a PLC or relay on other equipment, acknowledge alarms, and much more. This is ideal for installations where the meter is inaccessible behind a cover, or where an additional function key is needed for customized operation.

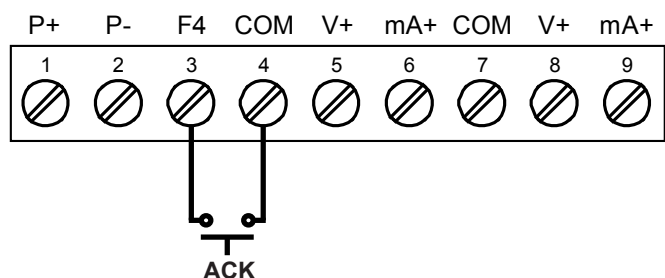

### Three Tier Password Protection

The ProtEX-MAX PD8-6080/81 offers 3 levels of password protection:

- Level 1 protection allows the operator use of only the 3 pre-configured function keys on the front panel without a password.
- Level 2 protection allows the operator use of only the function keys and the ability to change set points without a password.
- Level 3 protection restricts the operator from using the function keys and all meter configuration menus without a password.

### Advanced Linearization Capability

The ProtEX-MAX PD8-6080/81 includes a 32-point linearizer for PV1 & PV2 (all other PVs utilize two-point linearization). In non-linear level applications (i.e. some pumping or lift stations), it can easily compensate for submerged equipment or plumbing that displace usable volume. In addition to the 32-point linearization, the ProtEX-MAX can perform a square root or programmable exponent function on one or both analog inputs, Modbus inputs, any or all enabled PVs, or automatically calculate level in round horizontal tanks by inputting the length and height of the tank. Each input's linearization is performed independently prior to the input value being used in any math function.

### Dual Analog Input Scanning

The PD8-6080/81 has two process input channels (A & B) capable of accepting current (0-20, 4-20 mA) and voltage ( $\pm 10$ , 0-5, 1-5, 0-10 VDC). Each input is programmed separately, with independent input type selection and scaling. These inputs may be displayed individually as part of the customizable dual-line display, or used with a wide range of math functions. Each input has a custom unit or tag that may be displayed. A 24 V transmitter power supply is standard and may be used to power the inputs. Each analog input enabled counts toward the available 16 PVs that may be scanned. The scanner could be configured to scan a maximum of 14 Modbus PVs, 4 math channels, and both analog inputs.

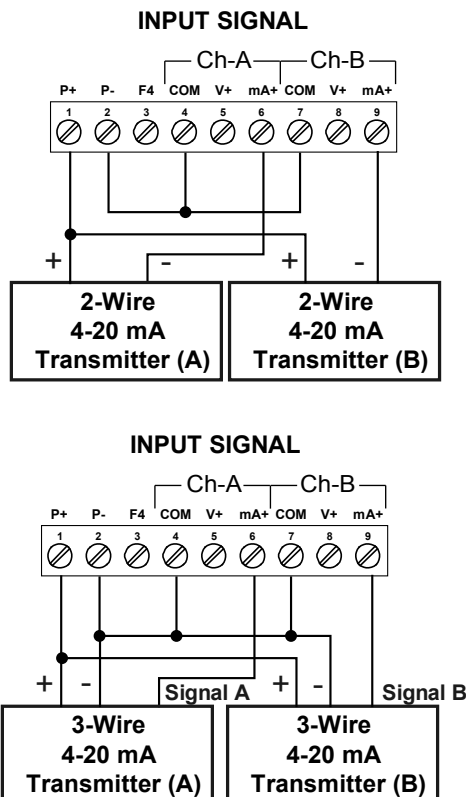

## INTEGRATED DIGITAL I/O AND SERIAL COMMUNICATIONS

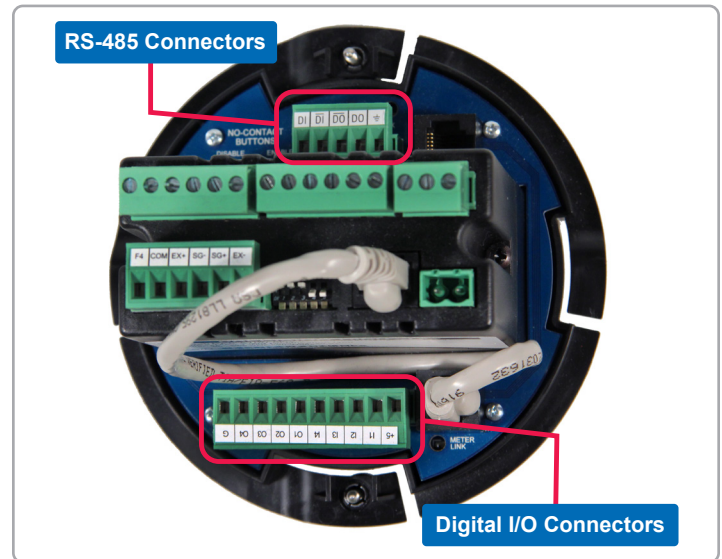

### Digital I/O Connections

Four digital inputs and four digital outputs come standard with the ProtEX-MAX. External digital inputs can function similarly to the front panel function keys or digital input F4. They can be configured to trigger certain events (i.e. acknowledge/reset alarms, reset max and/or min values, disable/enable all output relays, and hold current relay states), or provide a direct menu access point. The inputs can be used to configure the meter remotely using panel mount push buttons on a control station, giving the user remote control of the four front panel push buttons.

Digital outputs can be used to remotely monitor the ProtEX-MAX's alarm relay output states, or the states of a variety of actions and functions executed by the meter.

**Note:** The onboard digital inputs (1-4) are configured at the factory to function identically to the front panel pushbuttons (Menu, F1, F2, & F3) in order to work with the SafeTouch buttons. Changing the programming of the digital inputs will affect the function of the SafeTouch buttons.

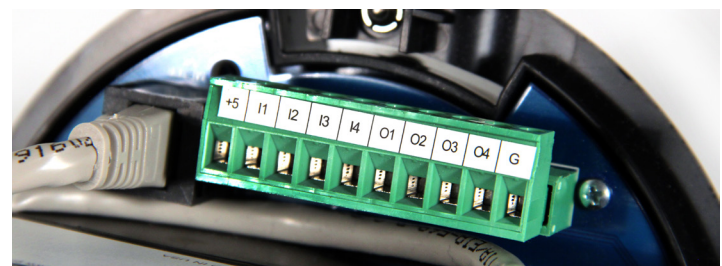

### Serial Communications Connections

ProtEX-MAX meters come with an RS-485 connection for serial communications with other digital devices. The industry standard Modbus® RTU protocol is included with every meter.

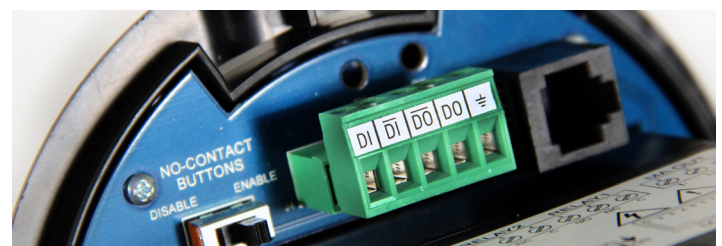

## OUTPUTS

Each output of the PD8-6080/81 may be assigned to an single analog input, Modbus PV, or math PV. The output will reflect the state of that assigned variable at all times during scanning.

### Relay Outputs

The ProtEX-MAX is available with four 3 A Form C relays (SPDT) with multiple power loss fail-safe options. Relays can be configured for proper protective action upon input loop break. Relay ON and OFF delay times are user adjustable. Up to eight front panel indicators show alarm and/or relay state. All relays can be configured for 0-100% deadband.

### Relay Operation/Configuration

There are powerful relay functions that can be configured in the ProtEX-MAX PD8-6080/81, including:

- Automatic reset only (non-latching)
- Automatic + manual reset at any time (non-latching)
- Latching (manual reset only)
- Latching with clear (manual reset only after alarm condition has cleared)
- Pump alternation control (automatic reset only)
- Sampling (activated for a user-specified time)
- User selectable fail-safe operation
- Relay action for loss (break) of 4-20 mA input signal
- Time delay (on and off), independent for each relay
- Manual control mode
- Interlock relay mode

### Analog Output

The isolated analog retransmission signal scales for any 4 mA and 20 mA display value. While the output is nominally 4-20 mA, the signal will accurately accommodate under- and over-ranges from 1 to 23 mA.

### Manual Output Control

Take control of any output with this feature. All relays can be forced ON or OFF, and the 4-20 mA output signal can be set to any value within its range. When the relays and 4-20 mA output are controlled manually, an LED labeled “M” is turned on and the associated Alarm LEDs (1-4) flash every 10 seconds indicating that the meter is in manual control mode.



### Isolated Transmitter Power Supply

A powerful 24 V @ 25 mA power supply is a standard feature on the ProtEX-MAX PD8-6080/81. It can be configured for 5, 10, or 24 V (default) by means of a simple internal jumper (see manual). An additional power supply (24 V @ 40 mA) is standard with the 4-20 mA output option.

### Sampling Function (PV Triggered Timed Relay)

The sampling function allows the operator to set a set point for a “sampling” relay. When the PV reaches that set point, it will close that relay’s contacts for a preset period of time (0.1 to 5999.9 seconds). An example of its use may be for beer/ale fermentation. When the batch reaches a certain pH, the relay contacts would close and alert someone or automatically take a sample of the batch. This function can be used whenever a timed relay output closure is required when the PV reaches a certain set point.

### Interlock Relay(s)

This function allows a process to use one or more very low voltage input signals or simple switch contacts to control the state of one or more internal “interlock” relays. A violation (i.e. loss of input, open switch, or open circuit) forces one or more N/O interlock relay contacts to open. One input can be used in series with a number of interlock switches, or up to eight inputs can be required to force-on one (or more) internal interlock relays. Please see Application Note AN-1008 on our website for more information. Requires PDA1044 Digital I/O module or use of on-board digital input F4.

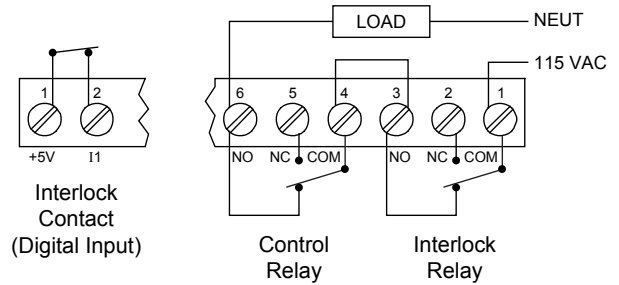

## SIGNAL INPUT CONDITIONING

Non-linear input signals (i.e. weirs & flumes, differential pressure, etc.) can be linearized with the ProtEX-MAX’s simple to use built-in signal input conditioning, such as: square-root extractor, exponential linearizer, round horizontal tank linearizer, or the ProtEX-MAX powerful general purpose 32-point linearizer (32 point for for PV1 & PV2 only - all other PVs use two linearization points).

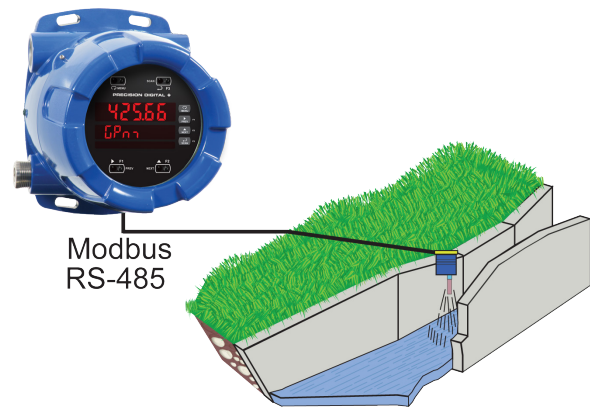

Weir Flow Calculated Using Exponential Signal Input Conditioning

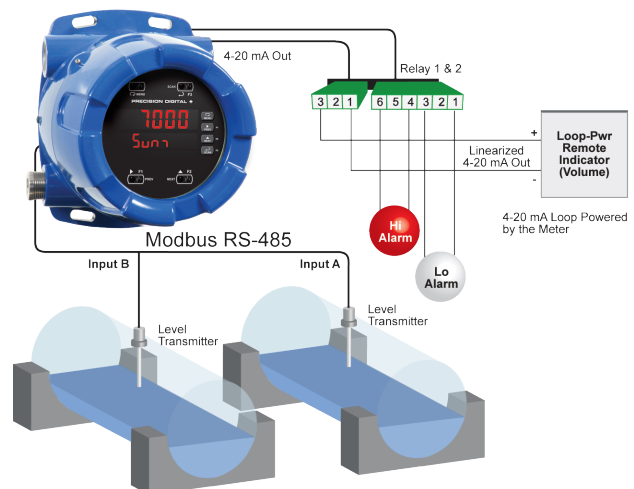

Round Horizontal Tank Signal Input Conditioning

## DIMENSIONS

Units: Inches (mm)

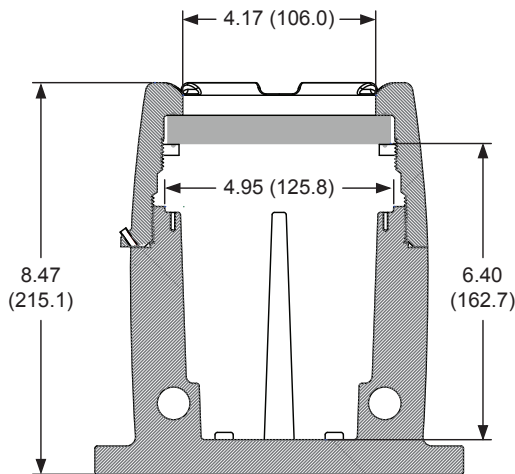
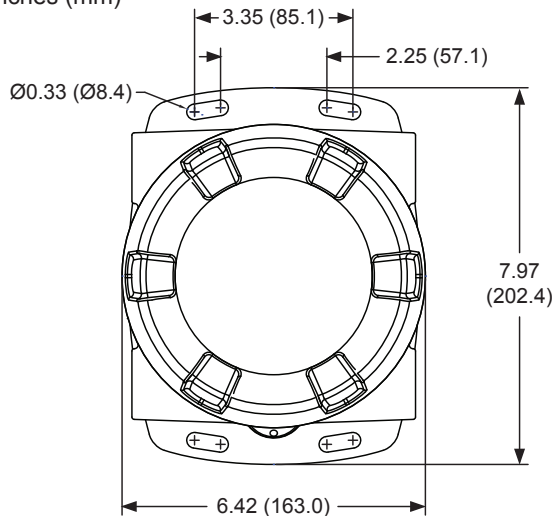

## CONNECTIONS

- Form C (SPDT) relays
- Two isolated supplies available even on 12/24 VDC input power models
- Removable terminal blocks
- 4 relays + isolated 4-20 mA output option

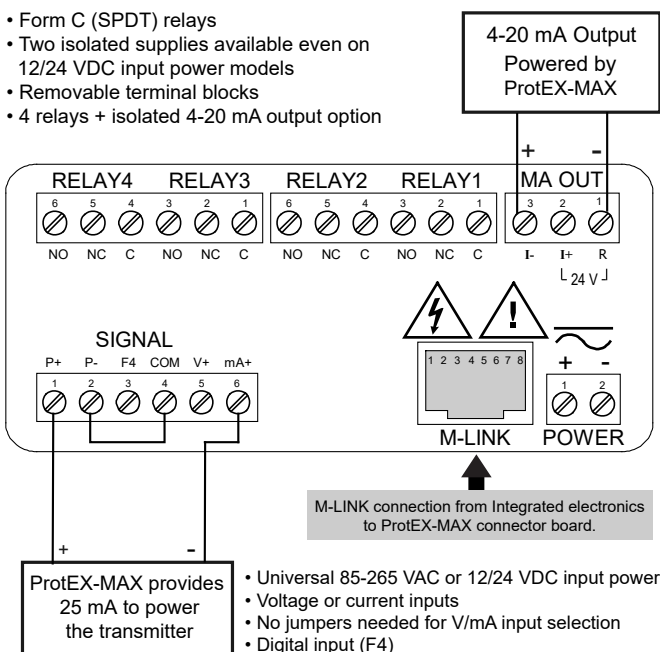

- ProtEX-MAX provides 25 mA to power the transmitter
- Universal 85-265 VAC or 12/24 VDC input power
- Voltage or current inputs
- No jumpers needed for V/mA input selection
- Digital input (F4)

## SPECIFICATIONS

Except where noted all specifications apply to operation at +25°C.

### General

**Input/Output:** Modbus RTU over RS-485, Two analog inputs (4-20 mA, ±10 V)

**Display:** Upper display: 0.60" (15 mm) high. Lower display: 0.46" (12 mm) high. Both are 6 digits (-99999 to 999999), red LEDs

**Display Intensity:** Eight user selectable intensity levels

**Display Scan Rate:** Master/Snooper: 1/second to once every 99.9 seconds. Slave: Dependent on master device (e.g. PLC)

**Overrange:** Display flashes 999999

**Underrange:** Display flashes -99999

**Display Assignment:** The top display may be assigned to PV (process values), Ch C (math channel), PV & units, tag & PV, tag-PV-units, C & units, tag-C-unit, Set point 1-8, max/min PV, max/min C. The bottom display may be assigned to all of the above, tag, or off. The tag and units are displayed alternately for 2 sec, when selected. Different tags & PVs may be selected to display on the top and bottom displays at the same time.

**Programming Methods:** Four SafeTouch through-glass buttons when cover is installed. Four internal pushbuttons when cover is removed.

**F4 Digital Input Contacts:** 3.3 VDC on contact. Connect normally open contacts across F4 to COM.

**F4 Digital Input Logic Levels:** Logic High: 3 to 5 VDC

**Noise Filter:** Programmable from 2 to 199 (0 will disable filter)

**Filter Bypass:** Programmable from 0.1 to 99.9% of calibrated span

**Recalibration:** All ranges are calibrated at the factory. Recalibration is recommended at least every 12 months.

**Max/Min Display:** Max (Peak) / min (Valley) readings reached by the process are stored until reset by the user or until power to the meter is cycled.

**Password:** Three programmable passwords restrict modification of programmed settings.

**Non-Volatile Memory:** All programmed settings are stored in non-volatile memory for a minimum of ten years if power is lost.

**Power Options:** 85-265 VAC 50/60 Hz, 90-265 VDC, 20 W max, or optional model with 12-24 VDC ±10%, 15 W max.

**Fuse:** Required external fuse: UL Recognized, 5 A max, slow blow; up to 6 meters may share one 5 A fuse.

**Isolated Transmitter Power Supply:** Terminals P+ & P-: 24 VDC ± 10%. Internally selectable jumper for 24, 10, or 5 VDC supply.

All models transmitter supply rated @ 25 mA max.

**Normal Mode Rejection:** Greater than 60 dB at 50/60 Hz

**Isolation:** 4 kV input/output-to-power line. 500 V input-to-output or output-to-P+ supply.

**Overvoltage Category:** Installation Overvoltage Category II: Local level with smaller transient overvoltages than Installation Overvoltage Category III.

**Environmental:** T6 Class operating temperature range Ta = -55 to 60°C  
T5 Class operating temperature range Ta = -55 to 65°C. Storage temperature range: -55 to 85°C (-67 to 185°F). Relative humidity: 0 to 90% non-condensing

**Max Power Dissipation:** Maximum power dissipation limited to 15.1 W.

**Connections:** Removable screw terminal blocks accept 12 to 22 AWG wire, RJ45 for external relays, digital I/O, and serial communication adapters.

**Mounting:** Two slotted flanges for wall mounting or NPS 1½" to 2½" or DN 40 to 65 mm pipe mounting. See Mounting Dimensions in the PD8-6060 instruction manual.

**Overall Dimensions:** 6.42" x 7.97" x 8.47" (W x H x D)  
(163 mm x 202 mm x 215 mm)

**Weight:** Aluminum: 14.7 lbs (6.67 kg); Stainless Steel: 23.5 lbs (10.66 kg)

**Warranty:** 3 years parts & labor

**USB Connection:** Compatibility: USB 2.0 Standard, Compliant

Connector Type: Micro-B receptacle

Cable: USB A Male to Micro-B Cable

Driver: Windows 98/SE, ME, 2000, Server 2003/2008, XP 32/64-Bit,

Vista 32/64-Bit, Windows 7 32/64-Bit, Windows 10 32/64-Bit

Power: USB Port

## Modbus Serial Communications

**Protocol:** Modbus RTU  
**Meter Address/Scanner ID:** 1 - 247, 256-259 (for Volts and mA)  
**Baud Rate:** 300 - 19,200 bps  
**Transmit Time Delay:** Programmable between 0 and 199 ms  
**Data:** 8 bit (1 start bit, 1 or 2 stop bits)  
**Parity:** Even, odd, or none with 1 or 2 stop bits  
**Byte-to-Byte Timeout:** 0.01 - 2.54 seconds  
**Turn Around Delay:** Less than 2 ms (fixed)  
**Operating Modes:** MASTER: Processes data read from Modbus RTU slave devices. It polls up to 16 process variables from 1 to 16 slave devices. The Master is capable of scanning the selected PVs, scale the data, trigger relays, perform math operations, and drive the analog outputs. SNOOPER: Listens to the Modbus traffic and picks up a specific register or registers being polled by a master device from a specific slave device and processes the data being read. The Snooper mode handles the data the same way as the Master. SLAVE: Processes data sent to it from a Modbus RTU master device.  
**PV Number:** PV1–PV16 Enable or disable the process variables to be polled by the Master.  
**Slave ID:** Assign the slave ID or address (1-247, 256-259 for mA or volts inputs) containing the process variables to be displayed by the selected PV.  
**Function Code:** Select which Modbus function code (03, 04, or 65) to use in reading the slave device.  
**Register Number:** 5 digit: 30001-39999, 40001-49999, or 1-65,536  
 6 digit: 300001-365536 or 400001-465536 (Function Code 65 N/A here)  
 Specifies which register(s) to read in the slave device. Range is dependent on Function Code selection (65, 04, or 03) and digits selection (5 or 6).  
**Data Type:** Select the data format that the slave device uses. Select between Short integer (2 byte), Long integer (4 byte), or floating point (4 byte), Signed or Unsigned (integer only) and byte order: 1234, 4321, 2143, or 3412 (big-endian vs. little-endian, or swapped).  
**Poll Time:** 1.0 to 99.9 sec. Time between read-commands (Master mode).  
**Slave Response Timeout:** 0.0 to 99.9 seconds: Time allowed for the slave to respond before the scanner generates a communication break condition. The master polls the slave 3 times before starting the response timeout timer. Slave/Snooper mode: Time the scanner will wait for new data before going into break condition. Slave mode: Programming 0 disables the timeout; the last value received will be displayed indefinitely.  
**Communication Breakdown:** Displays "b-ERR" after the Master has polled the slave device 3 times and the response timeout has elapsed. The Snooper and Slave modes go into break condition after no new data is received within the response timeout window. Relays can be programmed to go on, off, or ignore the break condition. The analog outputs can be setup to generate a fixed mA current when a break condition is detected.  
**Programmable Constants:** Constant P (Adder): -99999 to 999999, default: 0.000; Constant F (Factor): 0.00001 to 999999, default: 1.000  
**Math Functions:** Addition, difference, absolute difference, average, multiplication, division, max of A or B, min of A or B, draw, weighted average, ratio, concentration. See instruction manual for details.  
**Tag & Units:** 6-character, independent tag and units for each PV and math channel.  
**PV Format:** PD6080 default: Decimal format. PD6081 default: FT & IN, 1/8th or 1/16th; decimal format may be selected for bottom display indication.  
**Display Decimal Point:** Up to five decimal places or none: *d.ddddd* *ddd.dddd* *ddd.dddd* *ddd.dd* *ddd.d* or *dddddd*  
**Float Decimal Point:** Select the number of decimals to use for the floating point data expected from the slave or master device (this is independent from the display decimal point selection).  
**PV & Math Scaling:** All PVs and math channels may be scaled to represent the input data in any engineering unit.  
 Example: Level transmitter = 999.999 inches; to display in Ft-In-1/16th scale input 2 to display 83 Ft – 4 In – 0/16th.  
**Scan Mode:** Automatic: 1.0 to 99.9 seconds.  
 Manual: Front panel or digital inputs  
 Go on alarm: Continues scanning after an alarm is detected  
 Stop on alarm: Goes to the alarmed PV and stops scanning; press Scan to resume scanning.

Note: Refer to the ProVu® Modbus Register Tables located at [www.predig.com](http://www.predig.com) for details.

## Relays

**Rating:** 4 SPDT (Form C) internal and/or 4 SPST (Form A) external; rated 3 A @ 30 VDC and 125/250 VAC resistive load; 1/14 HP (≈ 50 W) @ 125/250 VAC for inductive loads.  
**Noise Suppression:** Noise suppression is recommended for each relay contact switching inductive loads.  
**Electrical Noise Suppression:** A suppressor (snubber) should be connected to each relay contact switching inductive loads to prevent disruption to the microprocessor's operation. Recommended suppressor value: 0.01 μF/470 Ω, 250 VAC (PDX6901).  
**Deadband:** 0-100% of span, user programmable  
**High or Low Alarm:** User may program any alarm for high or low trip point. Unused alarm LEDs and relays may be disabled (turned off).  
**Relay Operation:** automatic (non-latching), latching (requires manual acknowledge), sampling (based on time), pump alternation control (2 to 8 relays), Off (disable unused relays and enable interlock feature, manual on/off control mode).  
**Relay Reset:** User selectable via front panel buttons, digital inputs, or PC.  
 1. Automatic reset only (non-latching), when input passes the reset point.  
 2. Automatic + manual reset at any time (non-latching).  
 3. Manual reset only, at any time (latching).  
 4. Manual reset only after alarm condition has cleared (latching).  
**Time Delay:** 0 to 999.9 seconds, on & off relay time delays. Programmable and independent for each relay.  
**Fail-Safe Operation:** Programmable and independent for each relay.  
**Auto Initialization:** When power is applied to the scanner, relays will reflect the state of the input to the scanner.

## Isolated 4-20 mA Transmitter Output

**Output Source:** Process Variable 1-16, math channels C1-C4, set points 1-8, or manual control mode  
**Scaling Range:** 1.000 to 23.000 mA for any display range  
**Calibration:** Factory calibrated: 4.000 to 20.000 = 4-20 mA output  
**Analog Output Programming:** 23.000 mA maximum for all parameters: Overrange, underrange, max, min, and break  
**Communications Break:** Programmable mA output when a slave device does not reply within the response timeout  
**Accuracy:** ± 0.1% of span ± 0.004 mA  
**Temperature Drift:** 0.4 μA/°C max from 0 to 65°C ambient, 0.8 μA/°C max from -40 to 0°C ambient  
**Isolated Transmitter Power Supply:** Terminals I+ & R: 24 VDC ± 10%. Isolated from the input at >500 V. May be used to power the 4-20 mA output or other devices. All models @ 25 mA max.  
**External Loop Power Supply:** 35 VDC maximum  
**Output Loop Resistance:**

Power supply	Minimum	Maximum
24 VDC	10 Ω	700 Ω
35 VDC (external)	100 Ω	1200 Ω

## Dual Process Input

**Two Inputs:** Two analog inputs, each separately field selectable: 0-20 mA, 4-20 mA; ±10 V (0-5, 1-5, 0-10 V)  
**PV Analog Channel ID:** Ch-A mA: Assign PV to ID 256 or Ch-A volt: 257; Ch-B mA: Assign PV to ID 258 or Ch-B volt: 259  
**Accuracy:** ±0.03% of calibrated span ±1 count, square root & programmable exponent accuracy range: 10-100% of calibrated span  
**Temperature Drift:** 0.005% of calibrated span/±C max from 0 to 65°C ambient, 0.01% of calibrated span/°C max from -40 to 0°C ambient  
**Signal Input Conditioning:** Linear, square root, programmable exponent, or round horizontal tank volume calculation  
**Multi-Point Linearization:** 2 to 32 points for PV1 and PV2  
**Programmable Exponent:** 1.0001 to 2.9999  
**Low-Flow Cutoff:** 0-999999 (0 disables cutoff function) for PV1 and PV2  
**Input Impedance:** Voltage ranges: greater than 500 kΩ  
 Current ranges: 50 - 100 Ω (depending on resettable fuse impedance)  
**Input Overload:** Current input protected by resettable fuse, 30 VDC max. Fuse resets automatically after fault is removed.  
**Calibration Range:**

Input Range	Minimum Span Input 1 & Input 2
10 Ω	700 Ω
100 Ω	1200 Ω



**Enclosure**

**Material:** AL Models: ASTM A413 LM6 die-cast aluminum, copper-free, enamel coated. SS Models: ASTM A743 CF8M investment-cast 316 stainless steel

**Gasket:** Fluoroelastomer

**Rating:** NEMA 4X, IP68 Explosion-proof

**Color:** AL: Blue. SS: Silver.

**Window:** Borosilicate glass

**Conduits:** Four ¾" NPT threaded conduit openings

**Conduit Stopping Plugs:** Sold separately

**Flanges:** Two built-in flanges for wall and pipe mounting.

**Tamper-Proof Seal:** Cover may be secured with tamper-proof seal.

**Overall Dimensions:** 6.42" x 7.97" x 8.47" (W x H x D) (163 mm x 202 mm x 215 mm)

**Weight:** AL: 14.7 lbs (6.67 kg). SS: 23.5 lbs (10.66 kg).

**ATEX:** Flameproof protection

Ⓜ II 2GD

Ex db IIC Gb

Ex tb IIIC Db

IP66/IP68

Tamb: -55°C to +85°C

Certificate No.: Sira 19ATEX1252U

**IECEX:** Flameproof and dust protection

Ex db IIC Gb

Ex tb IIIC Db

IP66/IP68

Tamb: -55°C to +85°C

Certificate No.: IECEX SIR 19.0075U

**CSA:** Class I, Division 1, Groups A, B, C, D

Class II, Division 1, Group E, F, G

Class III

Ex db IIC Gb

Ex tb IIIC Db

Class I, Zone 1, AEx db IIC Gb

Zone 21, AEx tb IIIC Db

IP66/IP68/TYPE 4X

Tamb: -55°C to +85°C

Certificate No.: 80011200

**UL:** Class I, Division 1, Groups A, B, C, D

Class II, Division 1, Groups E, F, G

Class III

Class I, Zone 1, AEx db IIC Gb

Zone 21, AEx tb IIIC

Ex db IIC Gb

Ex tb IIIC Db

IP66/IP68/TYPE 4X

Tamb: -55°C to +85°C

Certificate Number: E518920

**Note:** The above approvals are for the enclosure only. See next column for approvals on the entire instrument.

**General Compliance Information**

**Electromagnetic Compatibility**

**Emissions**

EN 55022

Class A ITE emissions requirements

**Radiated Emissions:** Class A

**AC Mains Conducted Emissions:** Class A

**Immunity**

EN 61326-1

Measurement, control, and laboratory equipment

EN 61000-6-2

EMC heavy industrial generic immunity standard

**RFI - Amplitude Modulated:** 80 -1000 MHz 10 V/m 80% AM (1 kHz)

1.4 - 2.0 GHz 3 V/m 80% AM (1 kHz)

2.0 - 2.7 GHz 1 V/m 80% AM (1 kHz)

**Electrical Fast Transients:** ±2kV AC mains, ±1kV other

**Electrostatic Discharge:** ±4kV contact, ±8kV air

**RFI - Conducted:** 10V, 0.15-80 MHz, 1kHz 80% AM

**AC Surge:** ±2kV Common, ±1kV Differential

**Surge:** 1KV (CM)

**Power-Frequency Magnetic Field:** 30 A/m 70%V for 0.5 period

**Voltage Dips:** 40%V for 5 & 50 periods

70%V for 25 periods

Voltage Interruptions: <5%V for 250 periods

**Note:** Testing was conducted on meters with cable shields grounded at the point of entry representing installations designed to optimize EMC performance.

**Product Ratings and Approvals**

**CSA:** Class I, Division 1, Groups B, C, D

Class II, Division 1, Groups E, F, G

Class III, Division 1

Class I Zone 1 Ex db IIC

Zone 21 Ex tb IIIC T90°C

-55°C < Tamb. < +60° C; Temperature Code T6

-55°C < Tamb. < +65° C; Temperature Code T5

Enclosure Type 4X & IP66 / IP68

Certificate Number: 2531731

**Special Conditions for Safe Use:**

Use suitably certified and dimensioned cable entry device and/or plug. The equipment shall be installed such that the supply cable is protected from mechanical damage. The cable shall not be subjected to tension or torque. If the cable is to be terminated within an explosive atmosphere, then appropriate protection of the free end of the cable shall be provided. Cable must be suitable for 90°C.

**Year of Construction**

This information is contained within the serial number with the first four digits representing the year and month in the YYMM format.

## ORDERING INFORMATION

PD8-6080 Decimal Modbus Scanner • Aluminum Enclosure		
85-265 VAC Model	12-24 VDC Model	Options Installed
PD8-6080-6H0	PD8-6080-7H0	None
PD8-6080-6H7	PD8-6080-7H7	4 Relays & 4-20 mA Output

Note: 24 V Transmitter power supply standard on all models.

PD8-6080 Decimal Modbus Scanner • Stainless Steel Enclosure		
85-265 VAC Model	12-24 VDC Model	Options Installed
PD8-6080-6H0-SS	PD8-6080-7H0-SS	None
PD8-6080-6H7-SS	PD8-6080-7H7-SS	4 Relays & 4-20 mA Output

Note: 24 V Transmitter power supply standard on all models.

PD8-6081 F&I Modbus Scanner • Aluminum Enclosure		
85-265 VAC Model	12-24 VDC Model	Options Installed
PD8-6081-6H0	PD8-6081-7H0	None
PD8-6081-6H7	PD8-6081-7H7	4 Relays & 4-20 mA Output

Note: 24 V Transmitter power supply standard on all models.



PD8-6081 F&I Modbus Scanner • Stainless Steel Enclosure		
85-265 VAC Model	12-24 VDC Model	Options Installed
PD8-6081-6H0-SS	PD8-6081-7H0-SS	None
PD8-6081-6H7-SS	PD8-6081-7H7-SS	4 Relays & 4-20 mA Output

Note: 24 V Transmitter power supply standard on all models.

Accessories	
Model	Description
PDA-SSTAG	Stainless Steel Tag
PDAPLUG75	3/4" NPT 316 Stainless Steel Stopping Plug with Approvals
PDA7485-I	RS-232 to RS-422/485 Isolated Converter
PDA8485-I	USB to RS-422/485 Isolated Converter
PDA6848	Pipe Mounting Kit Zinc Plated
PDA6848-SS	Pipe Mounting Kit Stainless Steel

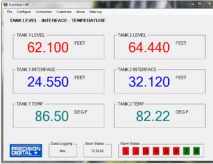

- Free Modbus Scanner Software
- Configure a Modbus Scanner
- Conveniently Monitor Critical Information
- Datalog from a PC
- Easy USB Connection

*Resident on PD8-6080/81 Modbus Scanners*

### Your Local Distributor is:



46, Jalan SS 22/21, Damansara Jaya,  
47400 Petaling Jaya,  
Selangor Darul Ehsan, Malaysia.

Email: [nog@nog.com.my](mailto:nog@nog.com.my)  
Website: [www.nog.com.my](http://www.nog.com.my)

### WARNING

Cancer and Reproductive Harm - [www.P65Warnings.ca.gov](http://www.P65Warnings.ca.gov)

### Disclaimer

The information contained in this document is subject to change without notice. Precision Digital Corporation makes no representations or warranties with respect to the contents hereof, and specifically disclaims any implied warranties of merchantability or fitness for a particular purpose.

©2022 Precision Digital Corporation. All rights reserved.