

PD765

Trident Series Process & Temperature Meters

 **TRIDENT**



PROCESS & TEMPERATURE

- 1/8 DIN Digital Panel Meter with NEMA 4X, IP65 Front
- 4-20 mA, ± 10 V, TC & RTD Field Selectable Inputs
- 4-Digit Display, 0.56" (14.2 mm) or 1.20" (30.5 mm)
- Shallow Depth Case Extends Only 3.6" (91.4 mm) Behind Panel
- Isolated 24 VDC @ 200 mA Transmitter Power Supply
- 2 Relays + Isolated 4-20 mA Output Options
- Free PC-Based MeterView™ Programming & Monitoring Software
- No Assembly Required
- Sunlight Readable Display
- Operating Temperature Range: -40 to 65°C (-40 to 150°F)
- UL & C-UL Listed. E160849; UL 508 Industrial Control Equipment
- Input Power Options: 85-265 VAC or 12-36 VDC
- Duplex Pump Controller with Alternation Capability
- External Contacts for Remote Button Operation (Trident X2 Only)
- USB, RS-232, & RS-485 Serial Communication Adapters Options
- Modbus RTU Communication Protocol Standard
- Copy Meter Settings to Other Trident Meters
- Max/Min Display
- High & Low Alarms with Multiple Reset Actions
- Light / Horn & Reset Button Accessory for Trident X2
- Control Station Accessory For Remote Operation of Trident X2
- 3-Year Warranty

PRECISION DIGITAL CORPORATION

**PRECISION
DIGITAL**

www.predig.com



Trident X2 meter mounted in PDA2301 enclosure with MOD-LH Light Horn accessory. See page 16 for details.

TABLE OF CONTENTS

OVERVIEW	3
PROCESS & TEMPERATURE INPUTS	4
ISOLATED TRANSMITTER POWER SUPPLIES	5
ADVANCED DISPLAY FEATURES	6
QUICK & EASY SCALE & PROGRAMMING METHODS	7
4-20 MA OUTPUT & RELAYS.	10
SERIAL COMMUNICATIONS	12
SIGNAL SPLITTER AND CONDITIONER ACCESSORIES	13
PHYSICAL FEATURES	14
VIDEOS TO WATCH	14
OPERATIONAL FEATURES	15
NEMA 4 & 4X FIELD ENCLOSURES	16
LIGHT / HORN & RESET BUTTON MOUNTED TO ENCLOSURE	17
CALIBRATOR & SIGNAL GENERATOR	19
DIMENSIONS	21
CONNECTIONS	21
SPECIFICATIONS	24
ORDERING INFORMATION	25

PD765 Trident Series Process & Temperature Meters

OVERVIEW

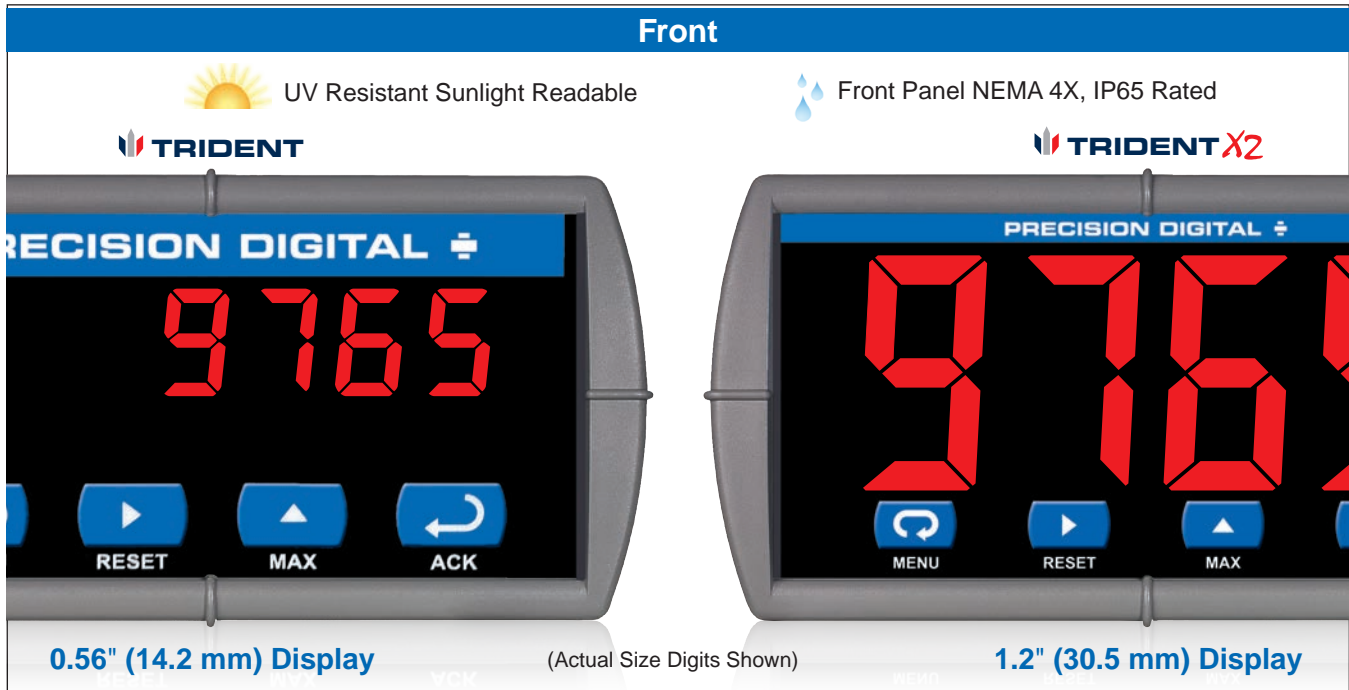

Trident and Trident X2 Connections (rear view)

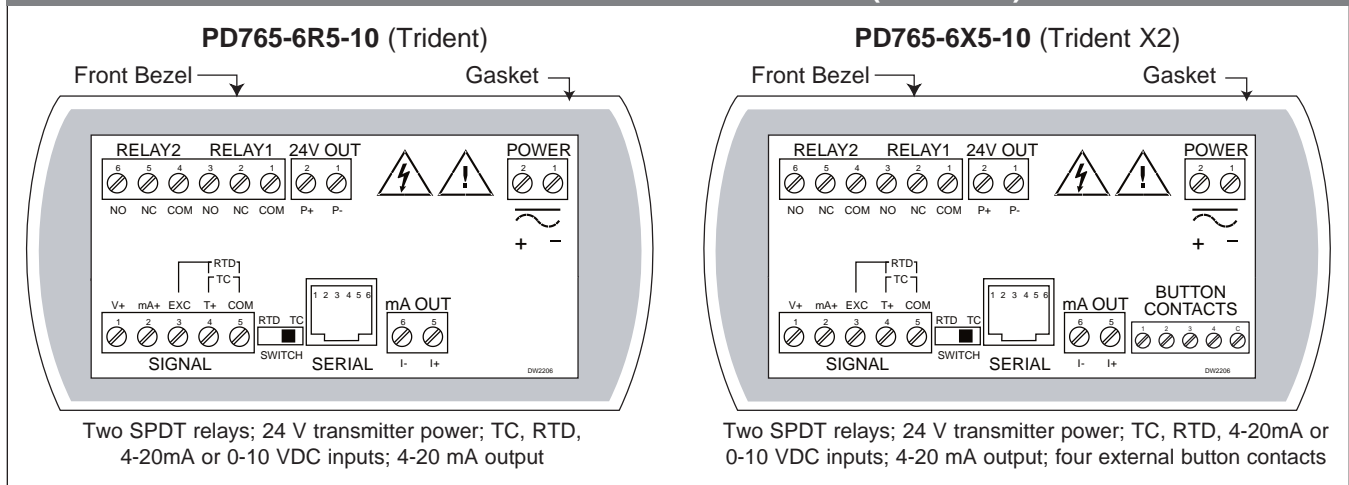

The Only 1/8 DIN Process & Temperature Meter You Will Ever Need

The PD765 Trident digital panel meter is one of the most versatile digital panel meters on the market and will satisfy a wide variety of process and temperature applications. The Trident can be field programmed to accept process voltage (0-5V, 1-5V, etc) and current (4-20 mA) inputs, 100 Ohm RTDs, and the four most common thermocouples.

One of the Trident's most useful features is its ability to provide 24 VDC to power the transmitter's 4-20 mA signal. It is housed in a shallow-depth, 1/8 DIN enclosure that features a NEMA 4X front panel and convenient mounting hardware. There are two power options for the Trident: 85 to 265 VAC or 12-36 VDC and the AC powered version can provide 24 VDC to power the transmitter if needed. Programming and setup can be performed with the four front panel pushbuttons, free MeterView™ software or using the GPO function.

Two relays and isolated 4-20 mA output options increase the utility of the Trident meter. The relays can be used for alarm or control applications. The 4-20 mA output provides an isolated retransmission of the input signal; especially useful for temperature inputs like thermocouples and RTDs.

The display height on the standard Trident meter is 0.56" (14.2 mm) and on the Trident X2 the display height is an astounding 1.2" (30.5 mm). The Trident X2 can be read easily from distances of up to 30 feet!

The intensity of the display on both versions of the Trident can be adjusted to compensate for various lighting conditions, including direct sunlight.

Both meters are available with all Trident features, although only the Trident X2 includes four external button contacts.

PROCESS & TEMPERATURE INPUTS

The Trident is factory calibrated to accept 4-20 mA, ± 10 VDC, type J, K, T, or E thermocouples and 100 Ω platinum RTDs. Process inputs can be scaled with or without applying an input for virtually any engineering units. Temperature inputs can be programmed to display in degrees Fahrenheit or Celsius and the type K thermocouple can display up to 2300°F.

Current & Voltage Inputs

Setting up the meter to accept a current or voltage input could not be easier. All setup is performed with the front panel buttons and there are no switches or jumpers to deal with.

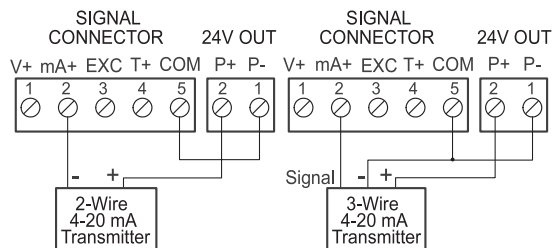

Transmitter Powered by Internal Supply (optional)

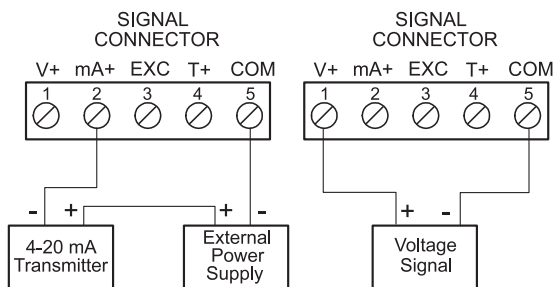

Transmitter Powered by External Supply

Current Overload Protection

To protect the instrument from unexpected current overload, the current input circuit contains a resettable fuse. The fuse limits the current to a safe level when it detects a fault condition, and automatically resets itself when the fault condition is removed.

Thermocouple & RTD Inputs

Setting up the Trident to accept a thermocouple or RTD input is simply a matter of setting a switch at the rear of the case and selecting the input type from the menu. The meter accepts J, K, T, or E type thermocouples as well as two, three, or four-wire 100 Ω platinum RTDs.

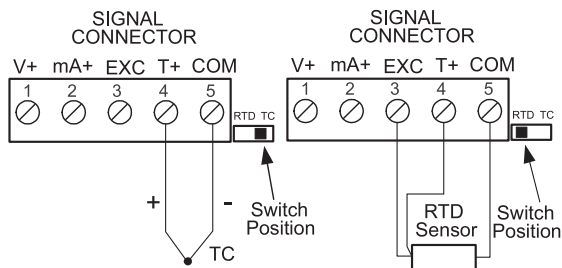

Temperature Inputs

The Trident meter accepts J,K,T or E thermocouples and 100 Ω platinum RTDs. For the T thermocouple and RTD, the user can display temperature to 1° or 0.1° resolution and the Type K thermocouple to 2300°F. In addition, these meters will operate down to -40°C with only minimal loss of accuracy.

Type	Range	Acc. (0-65°C)	Acc. (-40-0°C)	Resolution
J	-58° to 1382°F -50° to 750°C	$\pm 2^\circ\text{F}$ $\pm 1^\circ\text{C}$	$\pm 5^\circ\text{F}$ $\pm 3^\circ\text{C}$	1°
K	-58° to 2300°F -50° to 1260°C	$\pm 2^\circ\text{F}$ $\pm 1^\circ\text{C}$	$\pm 4^\circ\text{F}$ $\pm 2^\circ\text{C}$	1°
T	-292° to 700°F -180° to 371°C	$\pm 2^\circ\text{F}$ $\pm 1^\circ\text{C}$	$\pm 13^\circ\text{F}$ $\pm 7^\circ\text{C}$	1° or 0.1°
E	-58° to 1700°F -50° to 927°C	$\pm 2^\circ\text{F}$ $\pm 1^\circ\text{C}$	$\pm 11^\circ\text{F}$ $\pm 6^\circ\text{C}$	1°
RTD	-328° to 1382°F -200° to 750°C	$\pm 1^\circ\text{F}$ $\pm 1^\circ\text{C}$	$\pm 5^\circ\text{F}$ $\pm 3^\circ\text{C}$	1° or 0.1°

Display AC Current on a Trident Meter with the PDA6420 AC Current Transducer



- Nonintrusive Conversion of 30/60/120 Amps to 4-20 mA
- Split Core Convenience
- Compact Design
- +/-2% Full Scale Accuracy from 10% to 100% of Selected Range
- Field Mounting Tabs Provided

Visit www.predig.com/pda6420 for more details.

Display Flow Rate From a DP Transmitter

DP Flow via Square Root Extraction

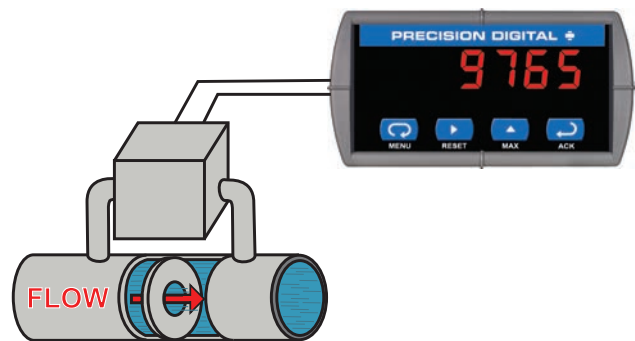

In this application, the PD765 is displaying flow rate by extracting the square root from the 4-20 mA signal from a differential pressure transmitter. The user selectable low-flow cutoff feature gives a reading of zero when the flow rate drops below a user selectable value.

ISOLATED TRANSMITTER POWER SUPPLIES

24 V @ 200 mA Transmitter Power Supply

One of the most useful features of the Trident PD765 is its built-in, isolated, 24 V @ 200 mA power supply to power the transmitter. This feature saves money by eliminating an external power supply and also simplifies wiring. The following diagrams illustrate how to wire the Trident so it will power the transmitter:

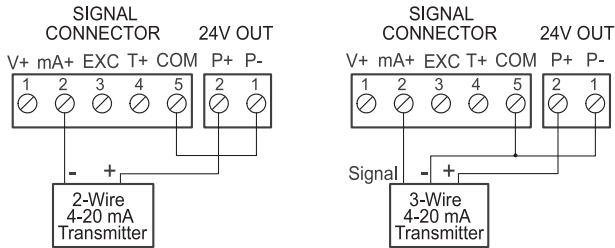

24 V @ 40 mA 4-20 mA Output Power Supply

Not only can the PD765 power the 4-20 mA input signal, but an additional power supply of 24 V @ 40 mA is available on select models to power the 4-20 mA output.

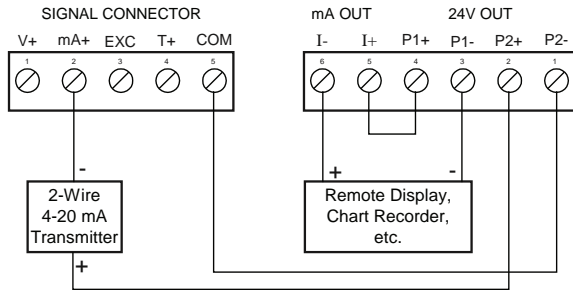

Connections for Tridents with -20 at end of part number

Resettable Fuse Prevents Current Overload

Another very useful aspect of the Trident is that the current input is protected against current overload by a resettable fuse. The fuse limits the current to a safe level when it detects a fault condition, and automatically resets itself when the fault condition is removed.

Isolated 4-20 mA Transmitter Output

The Trident's isolated 4-20 mA output option converts the Trident into a transmitter / loop isolator with a digital display; perfect for temperature applications!

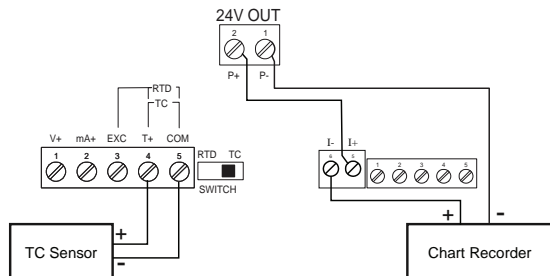

Other Uses for Transmitter Power Supplies

The most common use for these two power supplies is for the 200 mA transmitter power supply to power the field transmitter and 40 mA power supply to power the 4-20 mA output from the meter. However, these two power supplies can be used in other ways. For instance, some level transmitters require the use of a heated lens. The Trident's 200 mA power supply could be used to power both the heated lens and the 4-20 mA signal from the transmitter.

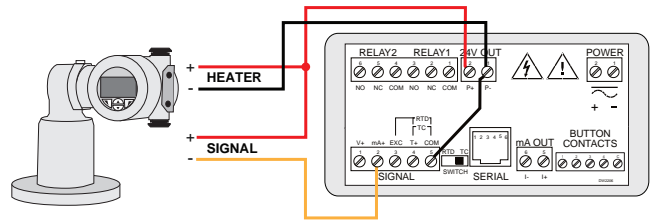

Trident X2 Powers Both the Heater and 4-20 mA Input Signal

External Power Supply for the Loop

For applications that require an external transmitter power supply, the same Trident is used and merely wired in a different fashion as the following diagrams illustrate:

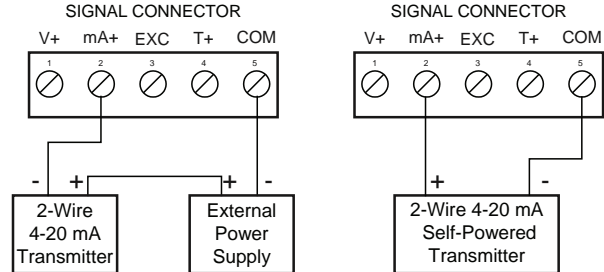

24 VDC Transmitter Power Supply

Precision Digital offers the PDA1024-01 for applications that require more than the 200 mA power that the Trident can provide.

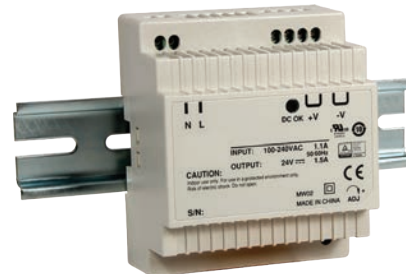

Specifications

Output Voltage: 24 VDC $\pm 10\%$ @ 1.5A rated current
Dimensions: 3.07" x 3.66" x 2.20"
 (78 mm x 93 mm x 56 mm) (W x H x D)

ADVANCED DISPLAY FEATURES

Four Full Digits

The display on the Trident is four full digits which means it can display numbers up to 9999. Many digital panel meters have displays of only 3½ digits which means they can display only to 1999. In practical terms, this means the Trident can display type K thermocouples to 2300°F and 4-20 mA signals up to 9,999.

Front Panel LEDs

The meter is supplied with two alarm points that include front panel LEDs to indicate alarm conditions. This standard feature is particularly useful for alarm applications that require visual-only indication.

Sunlight Readable Display

The intensity of the display on both versions of the Trident can be adjusted to compensate for various lighting conditions, including direct sunlight. In the advanced menu features menu, you can choose from eight levels of intensity depending on the visibility conditions.



The following diagram illustrates how to set the intensity on the Trident process and temperature meter:

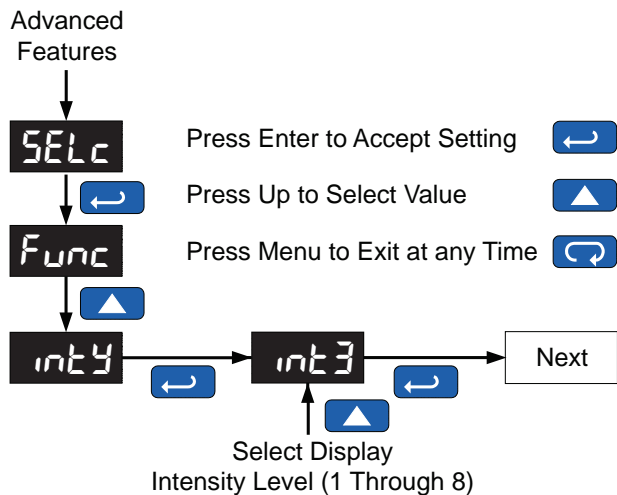

Two Display Sizes

The display height on the standard Trident meter is 0.56" (14.2 mm) and on the Trident X2 the display height is an astounding 1.2" (30.5 mm). The Trident X2 can be read easily from distances of up to 30 feet!

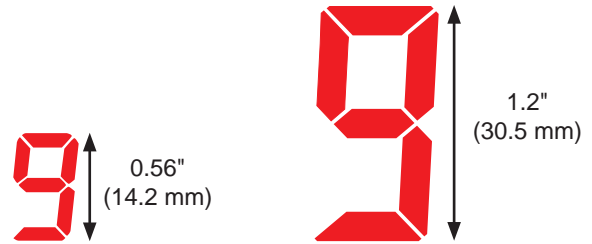

Trident Actual Size Digit

Trident X2 Actual Size Digit

Display & Toggle Maximum / Minimum Reading

The main function of the front panel buttons during operation is to display the maximum and minimum readings reached by the process or temperature inputs. The Trident allows you to toggle between the maximum and minimum readings of the process values. To display the maximum and minimum readings since the last reset/power-up, use the Up arrow/Max button.

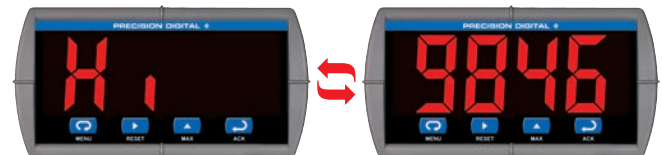

Display & Toggle Maximum Value

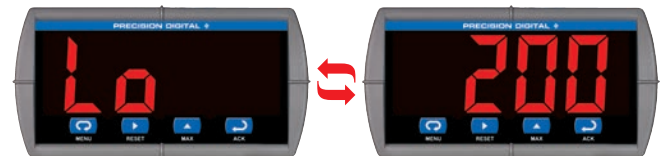

Display & Toggle Minimum Value

QUICK & EASY SCALE & PROGRAMMING METHODS

The Trident is easily setup and programmed using the simple four-button programming method. The meter can also be programmed using a PC and Precision Digital's free MeterView™ software or "cloned" with the Copy function. There is only one switch on the entire meter, no jumpers, and no need to ever open the case.

Free PC-Based MeterView™ Software



Note: Trident meter is not powered from USB connection and requires external power to be programmed.

MeterView™ software allows all PD765 Trident setup parameters to be programmed from a PC and to save the configuration settings to a file for reporting or programming other meters. For programming purposes, MeterView software connects to the Trident meter via the low-cost PDA8006 USB serial adapter pictured above.

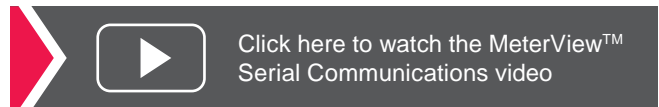

Meter Copy

The Copy function is used to copy (or clone) all the settings from one Trident meter to other Trident meters in less than 10 seconds. The Copy function is a standard feature on all Trident meters. The Copy feature does not require a serial communication adapter, it only requires the optional cable assembly (PDA7420).



Programming with Four Front Panel Buttons

The Trident's four front panel buttons keep the user in control of the programming process. To see how simple it is to program the Trident, check out the Virtual Meter at www.predig.com/tvm.

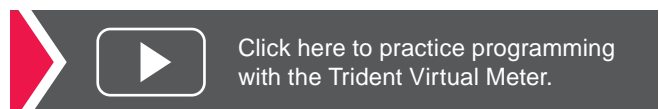

PD765 Trident Series Process & Temperature Meters

Programming From a PC with MeterView™

Precision Digital's free MeterView™ software allows all PD765 Trident setup parameters to be programmed from a PC and to save the configuration settings to a file for reporting or programming other meters. For programming purposes, MeterView software connects to the Trident meter via the low-cost PDA8006 USB serial adapter. Below are examples of the various windows used to configure, scale, set relays / alarms, and program other advanced features.

Configure Input

- Input type
- Temperature units
- Sensor type

File Tools Password

Input Scaling Relays/Alarms Advanced Info

Input Type: 4 to 20 mA

Temperature Units: Degrees F

Temperature Sensor: 100 Ohm Pt RTD (385)

Meter Scaling

- Scale input
- Decimal point
- No cryptic codes
- Simple to use

File Tools Password

Input Scaling Relays/Alarms Advanced Info

Current (mA)

Input 1: 4.00 Display 1: 4.00

Input 2: 20.00 Display 2: 20.00

Display Decimal Point: 2 Decimal

Voltage (V)

Input 1: 0.00 Display 1: 0.00

Input 2: 10.00 Display 2: 10.00

Display Decimal Point: 2 Decimal

Set Relays/Alarms

- Select reset mode
- Set/reset points
- Fail-safe operation
- On & off delays

Input Scaling Relays/Alarms Advanced Info

Relay/Alarm 1

Mode: Automatic Reset

Fail-Safe:

Set Point: 7.00 On Delay (sec): 0

Reset Point: 6.00 Off Delay (sec): 0

Relay/Alarm 2

Mode: Automatic and Manual Reset

Fail-Safe:

Set Point: 10.00 On Delay (sec): 0

Reset Point: 9.00 Off Delay (sec): 0

Advanced Settings

- Password
- Filter & bypass
- Transmit delay
- Display intensity level
- Function type
- Analog output scaling
- Sensor break

Input Scaling Relays/Alarms Advanced Info

Adjust Value: 0.0

Filter Value: 10

Bypass Value: 0.2%

Transmit Delay: 10 ms

Lockout Status:

Intensity: Level 8

Function Type: Linear

Cutoff Value: 0.00

Analog Output Option Installed

Analog Output (mA)

Display 1: 4.00 Output 1: 4.00

Display 2: 20.00 Output 2: 20.00

Sensor Break: 3.00

PD765 Trident Series Process & Temperature Meters

Save/Retrieve Configuration

MeterView™ software allows all PD765 Trident setup parameters to be programmed from a PC and to save the configuration settings to a file for reporting or programming other meters. For programming purposes, MeterView software connects to the Trident meter via the low-cost PDA8006 USB serial adapter.

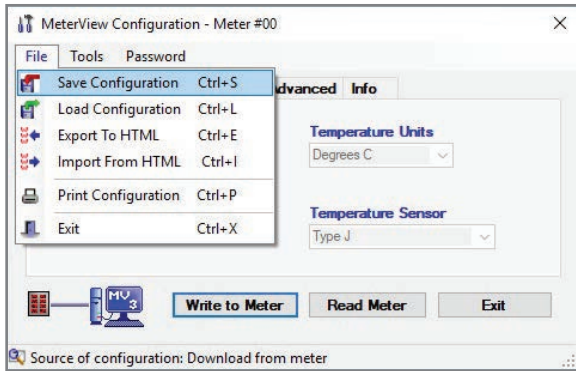

Data Acquisition

Digital panel meters make a great front end to a PC-based data acquisition system. They are easy to set up, can be used for a wide range of inputs, will power the transmitter, and best of all provide a local display of the process. Precision Digital has the perfect package with its Trident Digital Panel Meters, a wide selection of serial adapters and converters and free MeterView™ software. Data is displayed on the PC and written to a file that could then be imported into a spreadsheet or other application.

Data Logging up to 100 Trident Meters

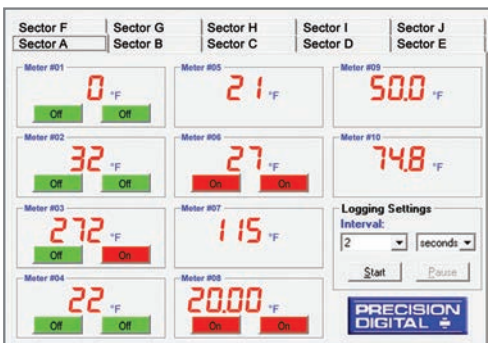

Sample File Generated by MeterView™

PD765 Log File						
Name: C:\MV3\logfile.htm		Created: 1/7/2019 5:34:12 PM				
Serial Port: COM 1	Connection speed: 2400 Baud	Logging rate: 1 update every 10 seconds				
Date & Time	Tag Number	Address	Display	Units	Relay 1	Relay 2
1/7/2019 5:34:12 PM	Tank 1 Level	06	17.70	Feet	P1 On	P2 Off
1/7/2019 5:34:12 PM	Tank 2 Level	07	18.18	Feet	P3 Off	P4 Off
1/7/2019 5:34:12 PM	Tank 3 Level	08	20.54	Feet	P5 On	P6 Off
1/7/2019 5:34:12 PM	Tank 1 Temp	09	74	°F	Off	Off
1/7/2019 5:34:12 PM	Tank 2 Temp	10	72	°F	Off	Off
1/7/2019 5:34:12 PM	Tank 3 Temp	11	72	°F	Off	Off
1/7/2019 5:34:22 PM	Tank 1 Level	06	17.58	Feet	P1 On	P2 Off
1/7/2019 5:34:22 PM	Tank 2 Level	07	18.04	Feet	P3 Off	P4 Off
1/7/2019 5:34:22 PM	Tank 3 Level	08	19.79	Feet	P5 Off	P6 Off
1/7/2019 5:34:22 PM	Tank 1 Temp	09	74	°F	Off	Off
1/7/2019 5:34:22 PM	Tank 2 Temp	10	72	°F	Off	Off

Relays for Alarm & Control Applications

Adding relays to the Trident meter turns it into a sophisticated alarm device as well as a powerful, yet simple, alternative to a more complicated PLC system for control applications. One such application would be pump control using the Trident's relays in pump alternation mode. The Trident can be equipped with two 3 A Form C (SPDT) internal relays. Relays are highly user-configurable as the following MV screen shot indicates:

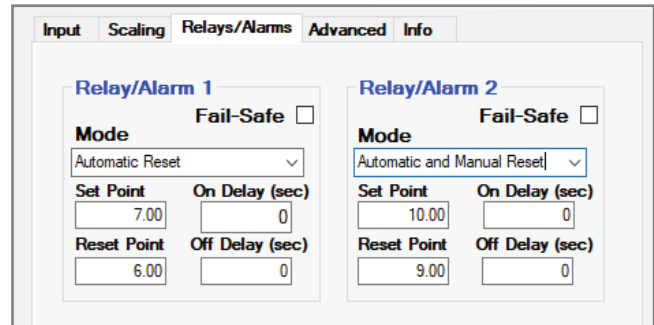

MeterView™ Software Specifications

System Requirements: Windows® 95/98/ME/NT4/2000/XP/Vista/7*/ Windows® 10

Communications: RS-232 adapter or RS-485 adapters with an RS-232 to RS-485 or USB to RS-485 converter may be used for communicating with the meters.

Number of Meters: Up to 100 meters simultaneously with addressing capability; minimum scan time for 100 meters: 60 sec

Meter Address: 00 to 99

Baud Rate: 300 bps to 19,200 bps; selection must match the baud rate selected in the meters.

Screen Update Rate: Dependent on system and meter settings. Rates of up to 10 meters/second are attainable at 19,200 bps.

Configuration: Configure meter settings one meter at a time.

Configuration Report: Save configuration to PDC file format or export to HTML for printing, cloning, or restoring meter.

Logging Interval: 2 seconds to 60 hours or manual

Manual Logging: Data saved to file when Log button is pressed.

Data Logging Report: Log data to HTML file format. All enabled meters are logged to a single file.

Alarm Notification: Pop-up message indicates new alarm condition. Alarm alert notification may be disabled.

Event Log: Important events are logged with date and time stamp.

Relay/Alarm Status: Indicate relay/alarm status with customized color and message label. Relay status indication may be disabled.

Units & Tag Number: Show engineering units and tag number information; these settings are not saved to the meter.

Relay Acknowledge: Relays may be acknowledged by clicking on corresponding Relay Status button. Meters must be set up for manual reset and Relay Mode must be enabled in MeterView™.

*Note: Windows 32-bit operating systems only

4-20 mA OUTPUT & RELAYS

Isolated 4-20 mA Analog Output

There are several uses for the Trident's isolated 4-20 mA output. For temperature applications, the isolated 4-20 mA output option turns the Trident X2 meter into a temperature transmitter with a huge display! For 4-20 mA input applications the isolated 4-20 mA output turns the Trident meter into a signal isolator with the convenience of local display of the process variable. The 4-20 mA output can also be reversed scaled.

Linear 4-20 mA Analog Output

For applications where the input was linearized by the Trident, the 4-20 mA output will represent that linearized value.

Convert Temperature Inputs to 4-20 mA Output with the PD765

The Trident X2, with the appropriate options, can be used as an isolated temperature transmitter with a big display by converting the thermocouple or RTD input into an isolated 4-20 mA output.

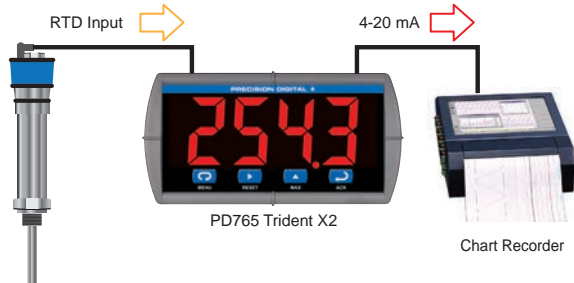

The 4-20 mA output can be reversed scaled such that 4 mA represents the high value and 20 mA represents the low value. For instance, a 4-20 mA output signal could be generated as the meter went from 100.0 to 0.0.

PD765 Provides 500 V of Isolation on the Output

The inputs and outputs of the PD765 Trident are electrically isolated to prevent ground loops and make wiring easier. All inputs, outputs and power supplies are fully isolated from one another.

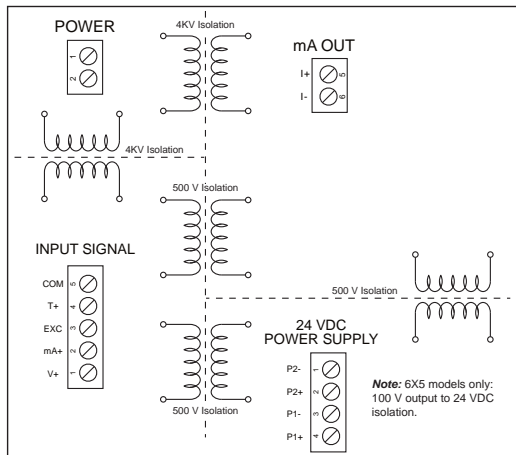

Connections

The Trident can provide 40 mA at 24 VDC to power the 4-20 mA output signal or an external power supply can be used:

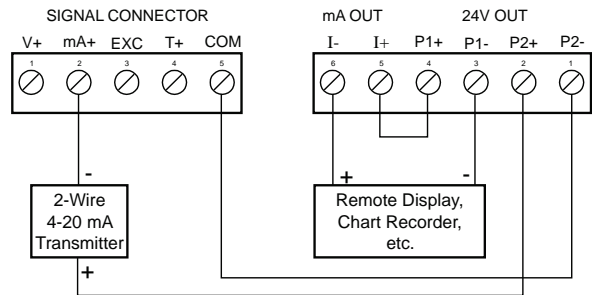

4-20 mA Output & Input Signal Powered by Meter

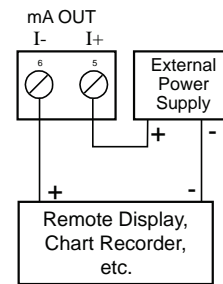

4-20 mA Output Powered Externally

The 4-20 mA output can either be programmed using the front panel push buttons or free MeterView™ software.

MeterView™ Software Programming

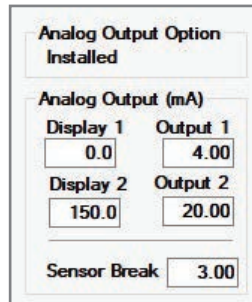

When a meter is programmed as shown to the left, the output will be 4.00 mA when the display reads 0.0 and the output will be 20.00 mA when the display reads 150.0.

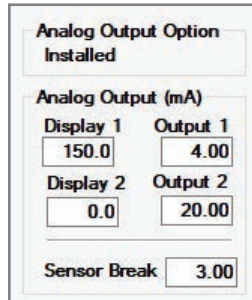

The meter can be set up for reverse scaling as shown to the left: the output will be 4.00 mA when the display reads 150.0 and the output will be 20.00 mA when the display reads 0.0

Sensor Break: Analog output value when TC or RTD sensor break is detected.

Relays for Alarm & Control Applications

Adding relays to the Trident meter turns it into a sophisticated alarm device as well as a powerful, yet simple, alternative to a more complicated PLC system for control applications. One such application would be pump control using the Trident's relays in pump alternation mode. The Trident can be equipped with two 3 A Form C (SPDT) internal relays. The relays are highly user-configurable as the following screen shot from MeterView™ indicates:

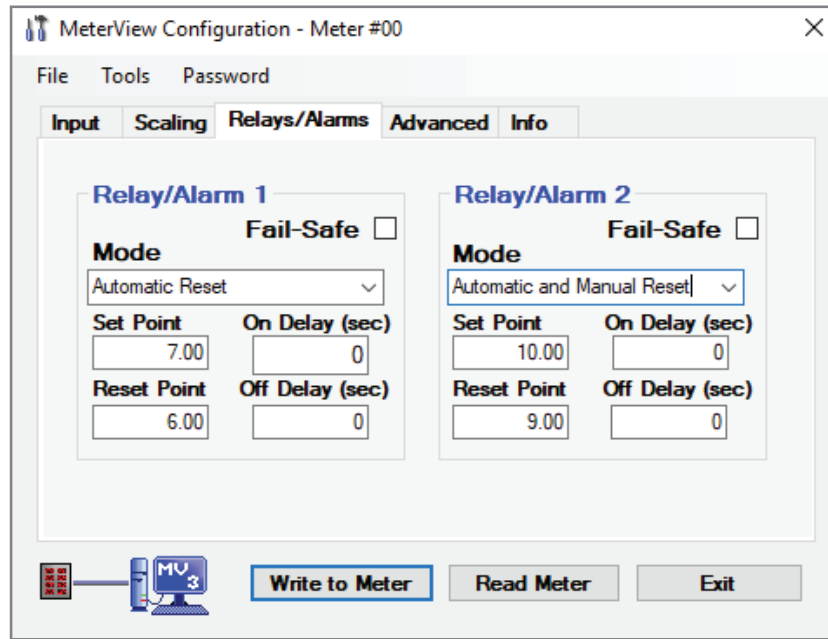

Setting Set and Reset Points (HI / LO Alarms)

All relays are independent of each other and may be programmed as high or low alarms with user desired set and reset points. Setting a set point above a reset point results in a high alarm and setting a set point below a reset point results in a low alarm. Alarms have 0 – 100% deadband and set and reset points may be set anywhere in the range of the meter.

Resetting the Relays (*Mode* in MV)

All relays are independent of each other and may be programmed to reset (*Mode* in MV) in the following ways:

- **Automatic:** Alarm will reset automatically once the alarm condition has cleared.
- **Automatic/Manual:** Alarm will reset automatically once the alarm condition has cleared but can also be reset using the ACK front panel button* at any time.
- **Latching:** Alarm must be reset manually and can be done so at any time. Press the ACK front panel button* at any time to clear the alarm.
- **Latching with Reset after Cleared:** Alarm must be reset manually and can only be done so after the alarm condition has cleared. Press the ACK front panel button* after the alarm condition has cleared to reset the alarm.

* Or by connecting an external button to terminal 4 on the external button contacts. (Trident X2 models only)

Time Delay (On and Off)

In many applications it is desirable to wait before turning off or on a relay – such as waiting for a process to settle before taking action. Each relay on the Trident PD765 can be programmed independently with on and off time delays of 0 to 999.9 seconds to achieve this.

Relays Auto Initialization

When power is applied to the meter, the front panel LEDs and alarm relays will reflect the state of the input to the meter.

Signal Loss Relay Operation (Sensor Break)

The meter can be programmed so that when it detects a break in the RTD or thermocouple signal, the relay will go to either the alarm or non-alarm state.

Note: This does not apply to voltage or 4-20 mA signals.

User Selectable Fail-Safe Operation

All relays are independent of each other and may be programmed for user selectable fail-safe operation. With the fail-safe feature activated, the relays will transfer to the alarm state on power loss to the meter.

Relay Connections

Relay connections are made to a six-terminal connector labeled RELAY1 and RELAY2.

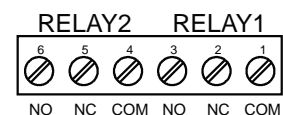

PD765 Trident Series Process & Temperature Meters

Pump Controller with Dual-Pump Alternation

The PD765 can be used as a low-cost pump controller when combined with a continuous level transmitter. One of the most common pump control application is shown below: controlling and alternating two pumps. The goal is to control the level between 1000 and 6000 gallons. The main pump turns on when the level reaches 6000 gallons and pumps down to 1000 gallons and then shuts the pump off. The next cycle, the backup pump turns on at 6000 gallons and shuts off at 1000 gallons. If at any time the active pump can't keep the level below 7000 gallons, the other pump would come on also.

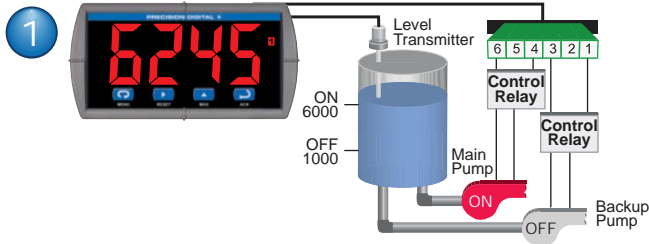

Relay #1 turns the main pump on at 6000 gallons and turns it off at 1000 gallons.

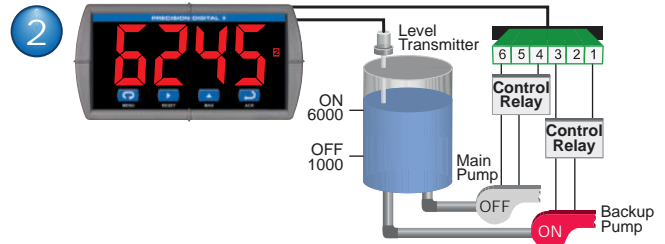

With the Pump Alternation feature activated, the next time the level reaches 6000 gallons relay #2 starts the backup pump.

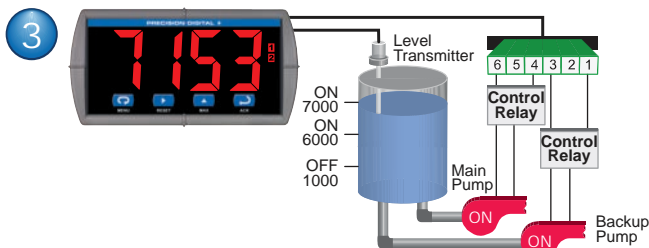

If the active pump is not able to keep up, and the level reaches 7000 gallons, the other relay will start the inactive pump as well.

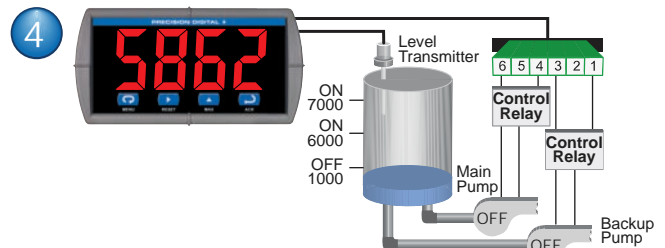

When the level falls below 1000 gallons both pumps will turn off.



If more than 2 relays are needed, consider the PD6000 ProVu meter. Visit predig.com/PD6000 for details.

SERIAL COMMUNICATIONS

Serial Adapters & Converters*

Precision Digital provides a variety of serial communication devices to interface the Trident meter with other devices.



PDA7420
Trident Meter
Copy Cable



PDA7232
Trident RS-232
Serial Adapter



PDA7422
Trident RS-485
Serial Adapter



PDA8006
USB Serial Adapter
for Programming
Meter with
MeterView Software



PDA8485-I
USB to RS-422/485
Isolated Converter



PDA7485-I
RS-232 to
RS-422/485
Isolated Converter



PDA8232-N
USB to RS-232
Non-Isolated
Converter

*All adapters and converters are sold separately and supplied with appropriate cables.



Click here for more information on
Serial Adapters and Converters.

SIGNAL SPLITTER AND CONDITIONER ACCESSORIES

Precision Digital offers signal splitter and conditioner accessories to increase the utility of the Trident meter. There is a model that splits the 4-20 mA output from the Trident meter into two isolated 4-20 mA outputs and there is a model that converts the 4-20 mA output from the Trident into a 0-10 VDC signal.



Features

- DIN Rail Mounting
- 1500 V Isolation
- 0.1% FS Accuracy
- Operating Temperature Range: -4 to 131°F (-20 to 55°C)

Split the Trident's 4-20 mA Output into Two 4-20 mA Signals

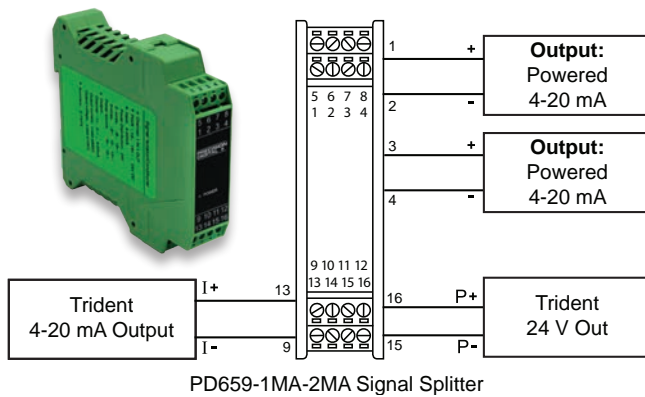

Convert the Trident's 4-20 mA Output into a 0-10 VDC Signal

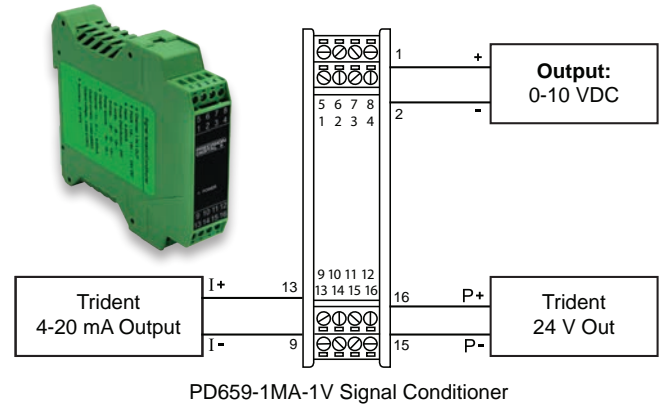

Mount the Meter and the Splitter / Conditioner in a NEMA 4X Enclosure



The Trident meter and the Splitter are mounted in a PDA2301 enclosure with backplane and DIN Rail. See page 16 for details on enclosures offered by Precision Digital Corp.



Need help selecting the right enclosure?
www.predig.com/esu

PHYSICAL FEATURES

The PD765 Trident is designed for ease-of-use in industrial applications. It is housed in a shallow depth case and includes a NEMA 4X front panel, wide operating temperature range, removable screw terminal connectors, snap in place mounting brackets, forgiving panel cutout requirement, and UL Listing for electrical safety. All of these features are backed by a 3-year warranty.

Wide Operating Temperature Range

The Trident can operate from -40 to 65°C (-40 to 150°F) meaning it can be installed in a wide variety of indoor and outdoor industrial applications. And over this range, the Trident will drift no more than 0.005% of calibrated span/°C max from 0 to 65°C ambient and 0.01% of calibrated span/°C max from -40 to 0°C ambient. See page 24 for details.

Removable Screw Terminal Connectors

Industrial applications require screw terminal connections for easy field wiring and the Trident goes one step further in convenience by making them removable also.

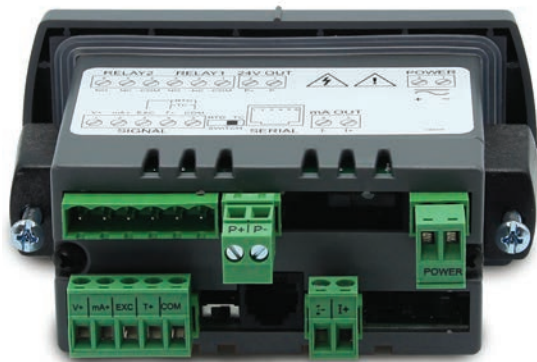

Easy Plug-in Removable Terminal Connectors



Forgiving Panel Cutout Requirement

The Trident's bezel has been oversized to allow for not perfectly executed panel cutouts where NEMA 4X seal is not required.

Over-Sized Bezel to Completely Cover Panel Cutouts



Secured-in-Place Rugged Mounting Brackets

If you're installing the Trident outdoors in the hot or cold weather, the last thing you want to do is fumble around with mounting brackets that don't stay in place. The Trident's mounting brackets can be easily secured into place and then screwed down to the panel. These brackets are rugged so they can be tightened to the panel to provide a solid NEMA 4X seal.

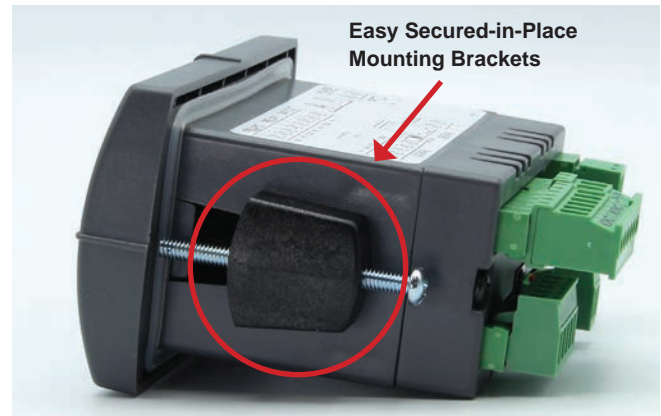

Type 4X / NEMA 4X Front Panel



Not only does the Trident's front panel UL Type 4X approval indicate it is waterproof, but it also indicates it is rugged. Part of the UL Type 4X test is to drop a 2-inch solid stainless steel ball from 8 feet on top of the meter's faceplate.

VIDEOS TO WATCH



Trident Live Feature Demonstration

Watch a simulation of a level application with the Trident X2 meter.



Trident Overview

Learn how the Trident can satisfy a wide variety of applications.

Videos can be found at predig.com/videos

OPERATIONAL FEATURES

Front Buttons & External Button Contacts

The main function of the front panel buttons during operation is to display the maximum and minimum readings reached by the process or temperature inputs as well as acknowledge relays.

1. Three Front Panel Button Operations

The following buttons can perform these functions:



2. External Button Contacts Available on Trident X2

The Trident X2 is equipped with four external button contacts that can be used to remotely operate the Trident X2's front-panel buttons. For instance, these button contacts can be used to program the meter and to remotely acknowledge/reset the relays:

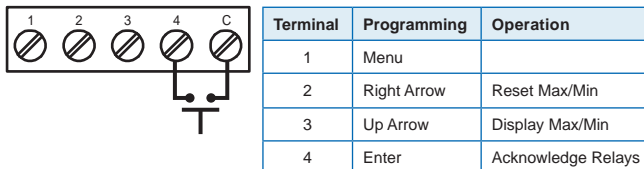

The external button contacts are particularly useful for wiring up a remote button to reset the relays as shown here:



Plastic Control Stations for Trident X2

The PDA2360 series of plastic control stations provide a convenient way to remotely program the Trident X2 meter via its four external button contacts. In addition, they also provide a means to acknowledge the relays with a remotely mounted button.

- Complete Pre-Assembled Stations
- Normally Open (NO) Spring Return Plastic Bezel Pushbuttons
- Trigger Action Turn to Release Pushbutton (PDA2360-E only)
- Control Station for Remote Operation of Light / Horn Reset Button
- IP65 / NEMA 4, 4X and 13 Rated
- Wall Mountable



PDA2360 Series Control Stations	
Model	Description
PDA2360-E	Emergency Stop Button
PDA2361-A	1 Black Ack Button
PDA2361-Q	1 Black Silence Button
PDA2364-MRUE	4 Black Buttons: Menu, Right, Up, Enter

Four-Position Control Station for Remote Operation of Trident PD765 X2 Buttons

The Trident PD765 X2's four programming and operations buttons can be remotely controlled by using the PDA2364-MRUE 4-button control station accessory as shown in the diagram below.

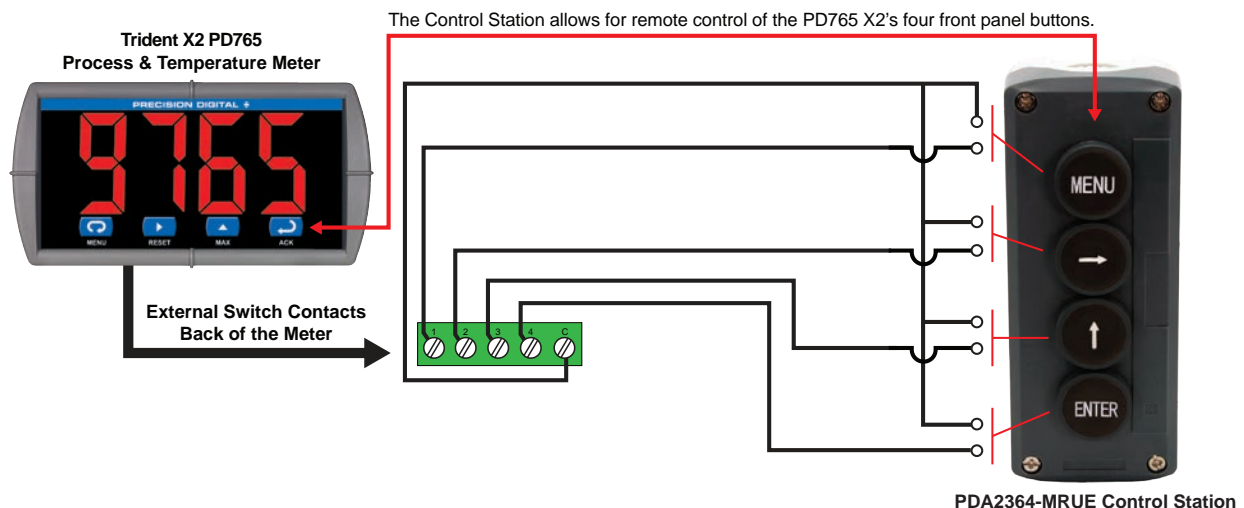

NEMA 4 & 4X FIELD ENCLOSURES

Precision Digital offers a variety of rugged enclosures that provide a high degree of protection against harsh operating environments. Thermoplastic and stainless steel NEMA 4X, and painted steel NEMA 4 enclosures for up to 10 Trident meters are available. In addition, Precision Digital offers a Light / Horn that can be mounted to most of these enclosures to provide visual and audible indication of alarms. Many enclosures also have sufficient space to house Precision Digital's model PDA1024-01 24 V power supply, signal splitters /isolators/conditioners and other devices.



Need help selecting the right enclosure?
www.predig.com/esu



Download free 3-D CAD files of these instruments to simplify your drawings!

predig.com/documentation-cad

Plastic Enclosures (Externally Mounted)

PDA2300 Series (Covers with Hinge & Latch)

This is Precision Digital's most economical line of enclosures for the Trident. The meter mounts through a hinged cover with a SS latch allowing for easy access to meter wiring. Enclosures are available for 1 through 10 Tridents. The enclosure is large enough to mount the PDA1024-01 24 V transmitter supply in.



PDA2301



PDA2310

PDA2800 Series (Covers with Screws)

This is Precision Digital's smallest line of enclosures for the Trident. The meter mounts through the cover that screws to the base of the enclosure. Available for 1 and 2 Tridents.



PDA2801



PDA2811



PDA2812

Plastic Enclosures (Internally Mounted)

PDA3400 Series (Covers with screws)

This is Precision Digital's only line of enclosures for the Trident where the meter is fully housed inside the enclosure. Enclosures are available for 1, 2 and 3 Tridents.



PDA3407



PDA3412

Stainless Steel Enclosures (Externally Mounted)

PDA2600 Series (Covers with Hinge & Latch)

This is Precision Digital's stainless steel line of enclosures for the Trident. The meter mounts through a hinged cover with a SS latch allowing for easy access to meter wiring. Enclosures are available for 1 through 6 Tridents.



PDA2604-1



PDA2606

Steel Enclosures (Externally Mounted)

PDA2700 Series (Covers with Hinge & Latch)

This is Precision Digital's painted steel line of enclosures for the Trident. The meter mounts through a hinged cover with a latch allowing for easy access to meter wiring. Enclosures are available for 1 through 6 Tridents.



PDA2704-1



PDA2706

LIGHT / HORN & RESET BUTTON MOUNTED TO ENCLOSURE

Trident X2 Meter in a PDA2301 Enclosure with MOD-LH Light / Horn and Reset Button. *Enclosure & MOD-LH Sold Separately. Assembly Required.*

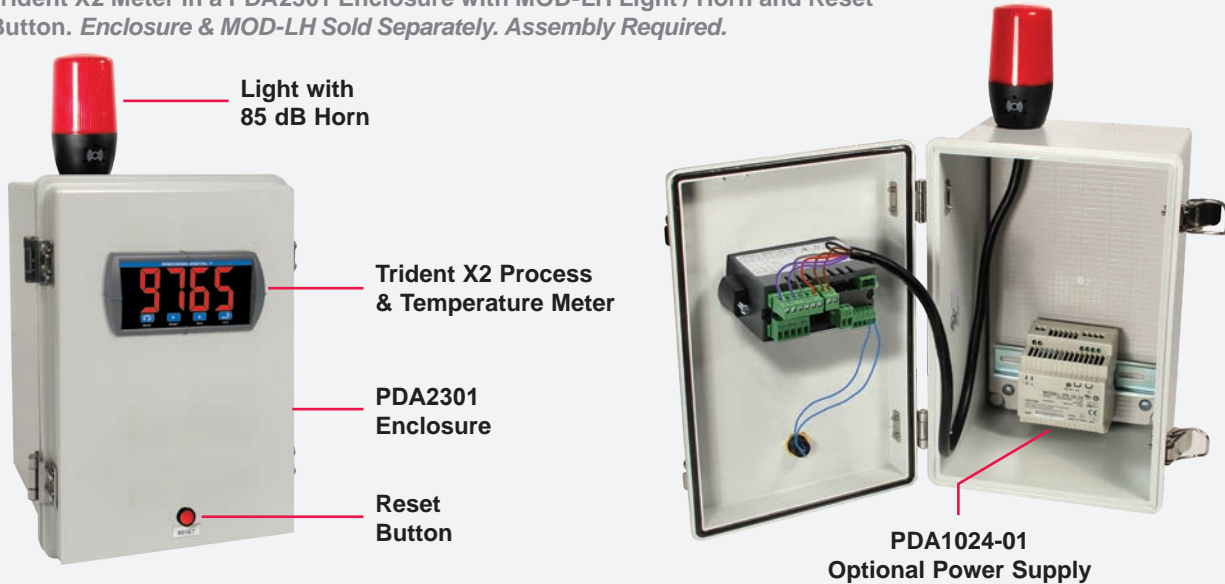

Note: The standard size display Trident meter will not work with the Light / Horn accessory because it does not contain external button contacts.

Overview

Precision Digital offers a wide variety of NEMA 4 and NEMA 4X enclosures that can be equipped with MOD-LH Light / Horn and Reset Button. When MOD-LH is ordered, the accompanying enclosure on the order comes with the holes pre-drilled for the Light / Horn and the Reset Button and the user performs the mounting and wiring. Meter and enclosure are sold separately. The Light / Horn and the Reset Button can also be ordered as separate items and the user performs all hole-drilling, mounting and wiring as desired. The light and horn can be controlled independently of each other via separate relays on the Trident X2 meter; and since the meter's relays can be reset in a variety of ways, there are several ways the Light / Horn option can operate. For instance, the horn can be programmed to silence at any time via the Reset Button or front panel button on the Trident X2, and light to reset automatically when the alarm clears as the following table illustrates:

Relay #	Connected to	Default Reset Mode
1	Flashing Light ⁽¹⁾	Auto reset
2	Horn	Silence with Reset Button at any time

1. Light can be wired to flash or stay steady on.
2. See page 11 for additional ways the relays can be programmed

Note: The Light / Horn accessory is powered from the 200 mA transmitter power supply; so when it is installed, there is less power available for the transmitter. See MOD-LH Light / Horn, Transmitter Power Supply specification on page 21 for details.

Dimensions

Units: Inches (mm)

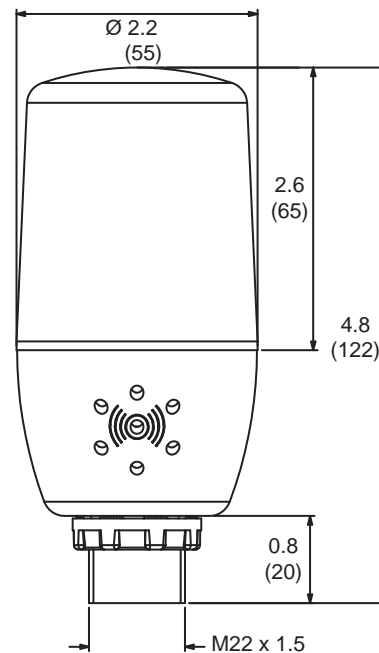

Click here to watch the Light / Horn Video

PD765 Trident Series Process & Temperature Meters

PDA1024-01 24 VDC DIN Rail Power Supply

For transmitters and sensors that require more than the 200 mA power that the Trident X2 can provide, use Precision Digital's PDA1024-01 24 VDC power supply as shown here.

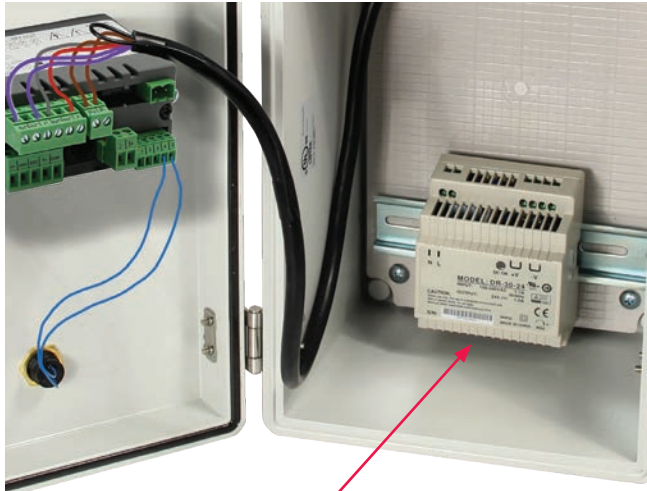

**PDA1024-01 Power Supply
Installed in a PDA2301 Enclosure**

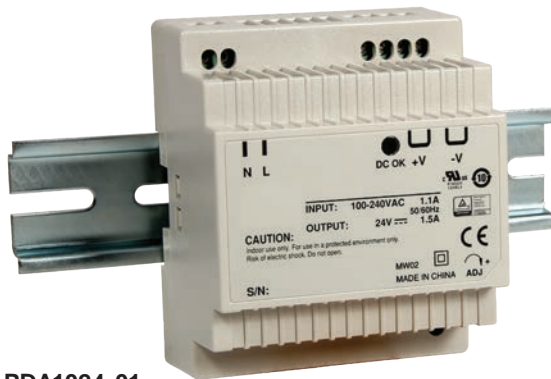

**PDA1024-01
24 VDC Power Supply**



Input Voltage	85 ~ 264VAC 120 ~ 370VDC
Output Voltage	24 VDC $\pm 10\%$ @ 1.5A rated current
Input Frequency	47 ~ 63Hz
AC Current	0.88A/115VAC 0.48A/230VAC
Connections	Two terminals provided for +V and -V to simplify wiring of multiple devices
Operating Temperature	-20° to 60°C
Safety Standards	UL60950-1, TUV EN60950-1 Approved, Design refer to EN50178
EMC	Compliance to EN55011, EN55022 (CISPR22) Class B, EN61000-3-2, -3 EN61000-4-2, 3, 4, 5, 6, 8, 11, ENV50204, EN55024, EN61000-6-1, EN61204-3 Light industry, Criteria A
Dimensions	3.07" x 3.66" x 2.20" (78 mm x 93 mm x 56 mm) (W x H x D)

Wiring Connections for MOD-LH Models

The following diagrams are for the MOD-LH models with a single color light using an internal power supply and using an external power supply.

Using Trident X2's Internal Power Supply

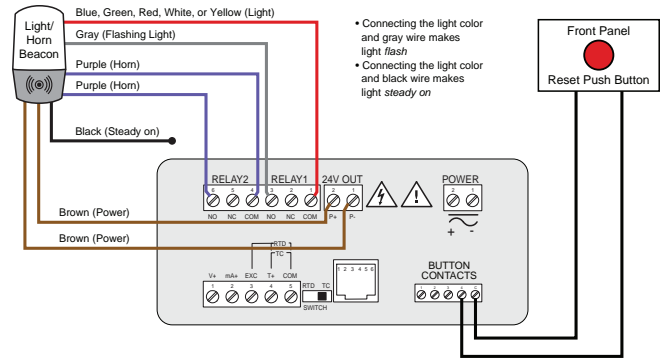

Using External Power Supply (PDA1024-01)

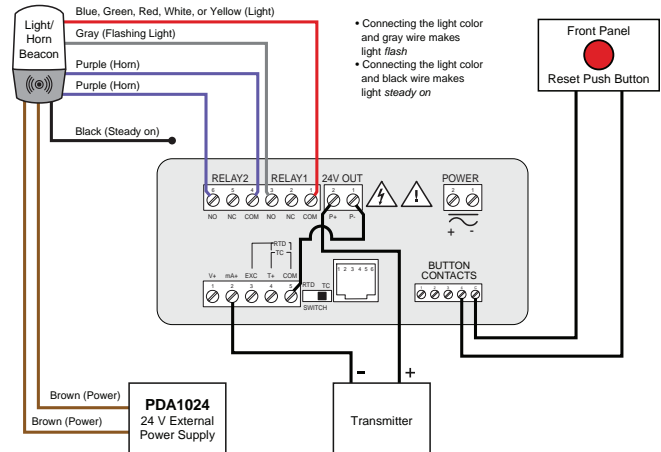

CALIBRATOR & SIGNAL GENERATOR

PD9501 Multi-Function Calibrator

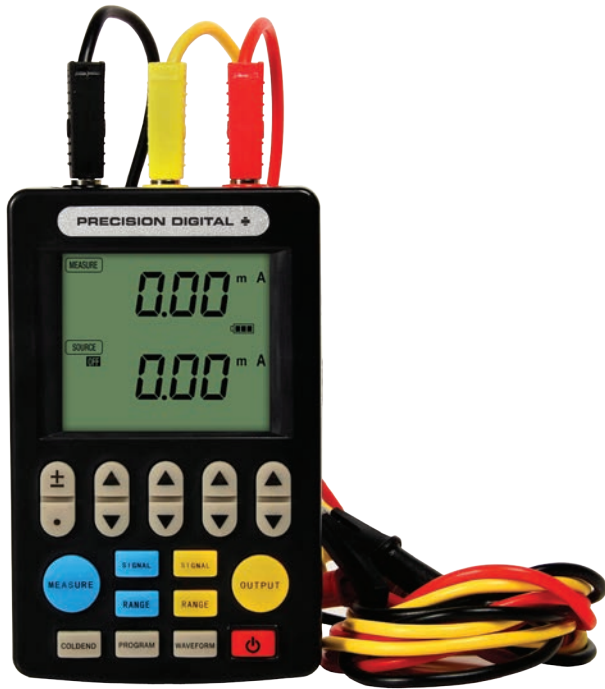

Overview

This PD9501 Multi-Function Calibrator has a variety of signal measurement and output functions, including voltage, current, thermocouple, and RTD.

Main Function

Voltage Signal: 0-30 V, 0-25 mV, 0-100 mV output and measurement.

Current Signal: Active and passive 0-25 mA, 4-20 mA output and measurement.

Thermocouple: K, E, J, T, R, B, S, N output and measurement. *Note: Output Range Starts from 0°C*

RTD: PT100 output and measurement.

Ohms: Output and measurement

Features

- Measure and Source T/Cs, RTDs, Ohms, Current, Voltage
- Compact & Lightweight
- Battery or USB Powered
- Descriptive LCD Display
- 24 V Power to Drive the Transmitter
- Auto Stepping & Auto Ramping
- Selective Auto Off Mode
- LCD includes an LED backlight

PD9502 4-20 mA / 0-10 VDC Low-Cost Signal Generator



Overview

The PD9502 is a low-cost, compact, simple to use 4-20 mA or 0-10 VDC signal generator. It can easily be set for 0-20 mA, 4-20 mA, 0-10 V or 2-10 V ranges. Signal adjustment is made with a one-turn knob. A 15-27 VDC wall plug is provided with the instrument. Optional USB power bank is available.

Features

- 0-20 / 4-20 mA or 0-10 / 2-10 VDC Ranges
- Low-Cost
- Simple to Use
- Compact Size
- 4-Digit LED Display
- One-Turn Adjustment Knob
- $\pm 0.5\% \pm 1$ Count Accuracy
- Power 15-27 VDC or USB Power Bank

Explosion-Proof Version of the Trident X2

Same Huge Display | Same Features



The Trident X2 meter is available as a fully approved ProtEX-MAX explosion-proof meter with all the features of the panel mount Trident! This means you can install the ProtEX-MAX version of the Trident X2 virtually anywhere and still get 24 VDC transmitter power supply, two relays, 4-20 mA output and field selectable inputs. In addition, the ProtEX-MAX version of the Trident comes with RS-485 serial communications with Modbus RTU as a standard feature. You can also program and operate the ProtEX-MAX in a hazardous area without opening the cover by using the SafeTouch through glass buttons.

PD8-765
Explosion-Proof
Process &
Temperature Meter

4-20 mA, ± 10 V, TC & RTD Inputs
Large 1.2" (31 mm) 4-Digit Display
Explosion-Proof, IP68, NEMA 4X Enclosure
Modern, Sleek and Practical Enclosure

PD765 Trident Series Process & Temperature Meters

DIMENSIONS

Units: Inches (mm)

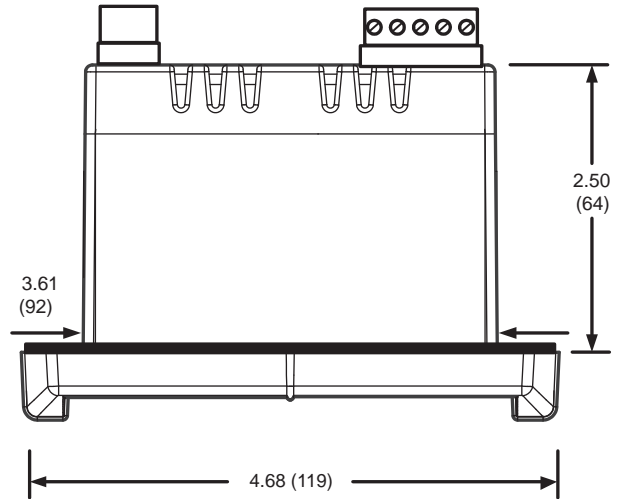
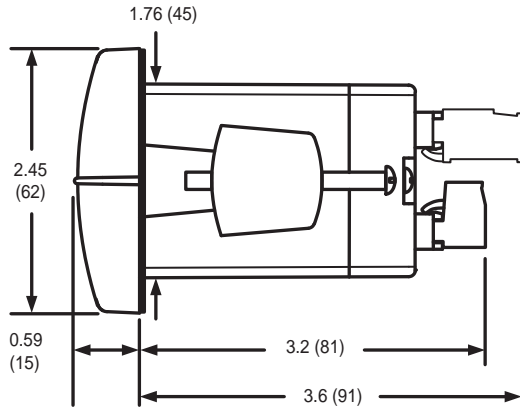

Notes:

1. Panel cutout required: 1.772 x 3.622 (45 x 92)
2. Panel thickness: 0.040 – 0.250 (1.0 – 6.4)
3. Mounting brackets lock in place for easy mounting



Download free 3-D CAD files of these instruments to simplify your drawings!

predig.com/documentation-cad

CONNECTIONS

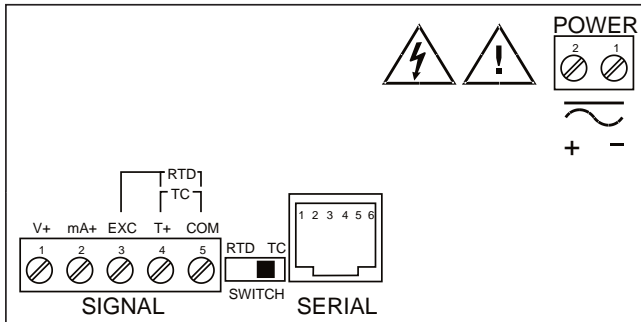

PD765-6R0-00, PD765-7R0-00

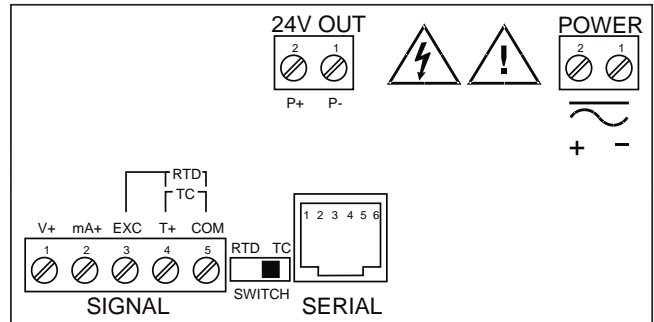

PD765-6R0-10

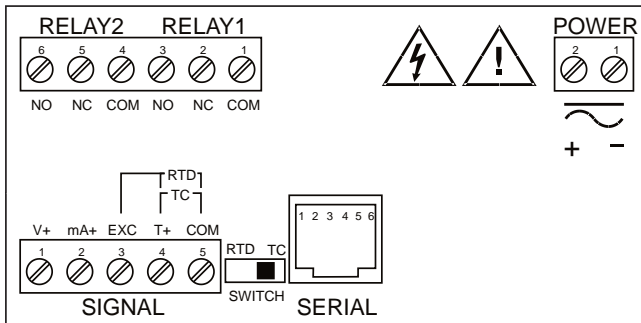

PD765-6R2-00, PD765-7R2-00

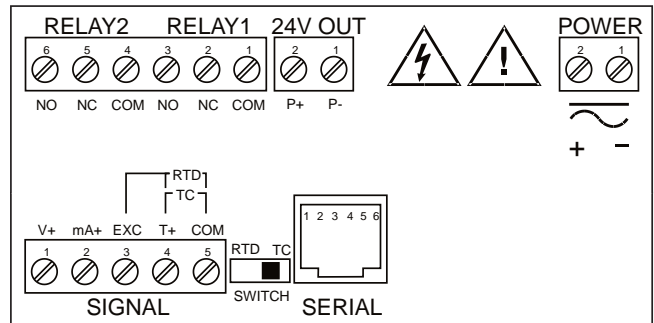

PD765-6R2-10

CONNECTIONS (continued)

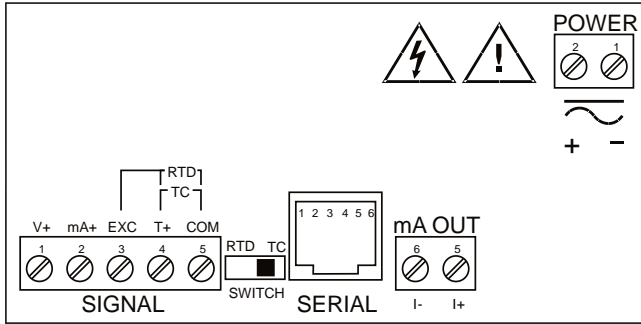

PD765-6R3-00, PD765-7R3-00

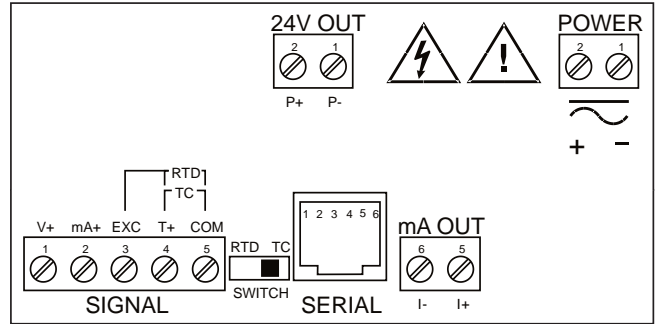

PD765-6R3-10

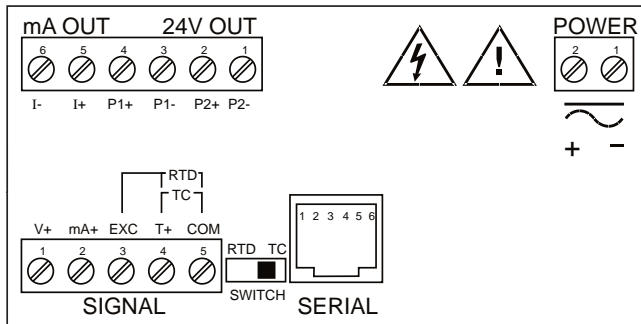

PD765-6R3-20

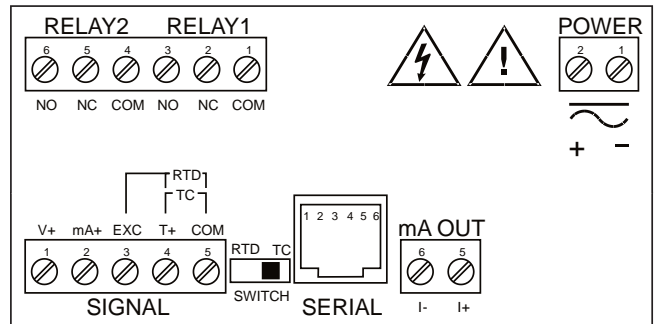

PD765-7R5-00

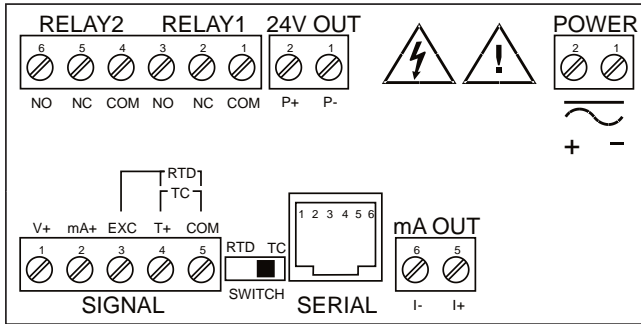

PD765-6R5-10

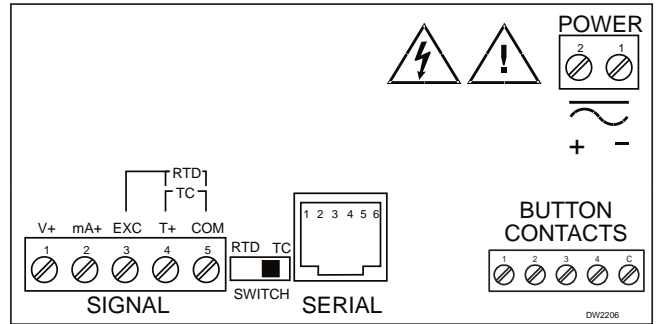

PD765-6X0-00, PD765-7X0-00

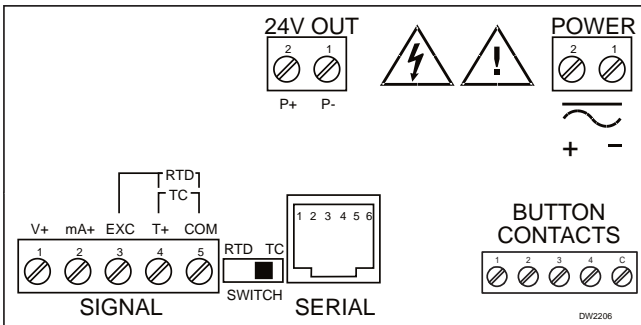

PD765-6X0-10

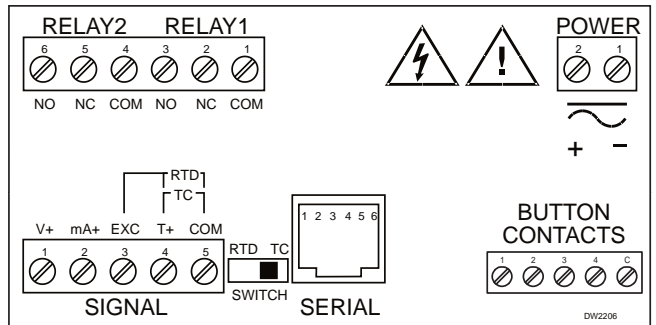

PD765-6X2-00, PD765-7X2-00

Note: The Trident PD765 does not have external button contacts like the PD765 X2, so it cannot be used with the Light / Horn accessory.

CONNECTIONS (continued)

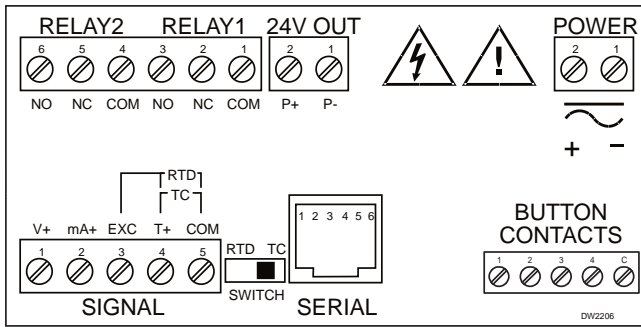

PD765-6X2-10

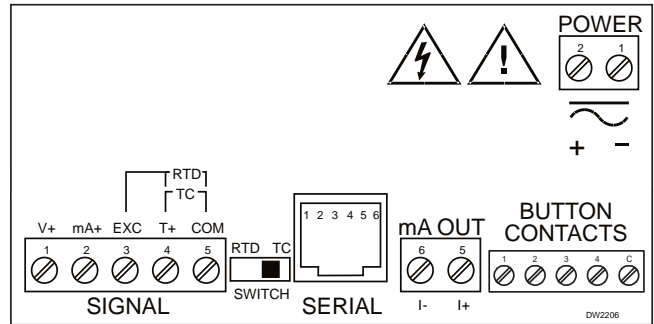

PD765-6X3-00, PD765-7X3-00

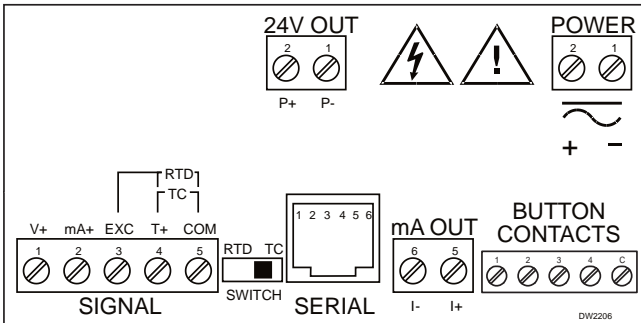

PD765-6X3-10

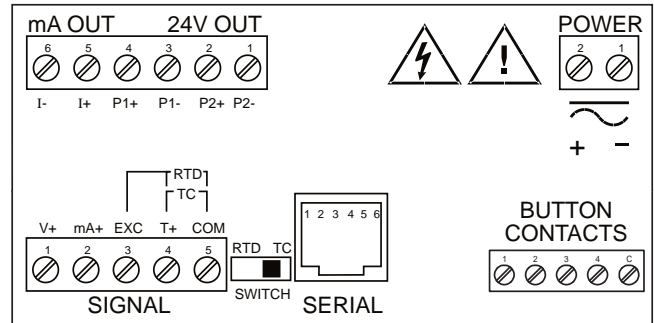

PD765-6X3-20

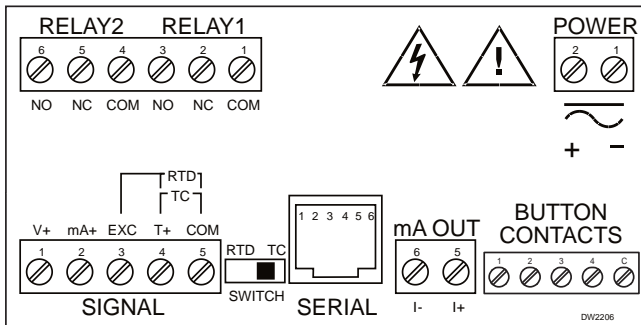

PD765-7X5-00

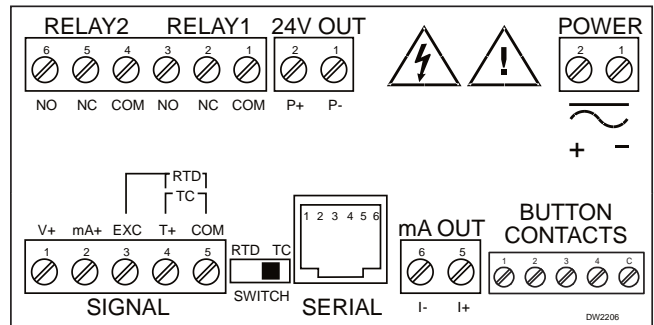

PD765-6X5-10

PD765 Trident Series Process & Temperature Meters

SPECIFICATIONS

Except where noted all specifications apply to operation at +25°C.

General

Display: Trident: 0.56" (14.2 mm);

Trident X2: 1.20" (30.5 mm) red LED,

4 digits (-1999 to 9999)

Display Intensity: Eight user selectable levels

Front Panel: NEMA 4X, IP65; panel gasket provided

Programming Methods: Four front panel buttons, cloning with Copy feature, PC with MeterView™ software, and Modbus registers.

Noise Filter: Programmable 2 to 199 (0 will disable filter)

Display Update Rate: Process/RTD: 3.7-5/sec; TC: 1.8-2.5/sec

Overrange: Display flashes 9999

Underrange: Display flashes -1999

Recalibration: All inputs are calibrated at the factory; recalibration is recommended at least every 12 months.

Max/Min Display: Stored until reset by user or meter is turned off.

Password: Restricts modification of programmed settings.

Non-Volatile Memory: Settings stored for a minimum of 10 years.

Power Options: 85-265 VAC, 50/60 Hz; 90-265 VDC, 20 W max or 12-36 VDC; 12-24 VAC, 6 W max.

Required Fuse: UL Recognized, 5 A max, slow-blow; up to 6 meters may share one fuse.

Normal Mode Rejection: 64 dB at 50/60 Hz

Isolation: 4 kV input/output-to-power line; 500 V input-to-output or output-to-24 VDC supplies. -6R5 & -6X5 models only: 100 V output-to-24 VDC supply

Operating Temperature: -40 to 65°C (-40 to 149°F)

Storage Temperature: -40 to 85°C (-40 to 185°F)

Relative Humidity: 0 to 90% non-condensing

Connections: Power & Signal: removable screw terminal blocks accept 12 to 22 AWG. Serial: RJ11 header, standard on all meters.

Enclosure: 1/8 DIN, high impact plastic, 94V-0, color; gray

Weight: 9.5 oz (269 g) (including options)

UL File Number: E160849; UL 508 Industrial Control Equipment

Warranty: 3 years parts & labor. See Warranty Information and Terms & Conditions on www.predig.com for complete details.

Process Inputs

Inputs: 0-20 mA, 4-20 mA, 1-5 V, ±10 V

Transmitter Supply: Isolated, one or two transmitter supplies

P1: 24 VDC ±10% @ 200 mA max (-10 option)

P1 & P2: 24 VDC ±10% @ 200 mA & 40 mA max (-20 option)

Accuracy: ±0.05% FS ±1 count; square root: ±0.1% FS ±2 counts

Function: Linear or square root

Low-Flow Cutoff: 0 to 9999 (0 disables cutoff function)

Decimal Point: Up to 3 decimals.

Calibration: Scale without signal or calibrate with signal source

Calibration Range: User programmable over entire range of meter

Input Impedance: Voltage range: greater than 1 MΩ,

Current range: 50-100 Ω, varies with resettable fuse impedance

Input Overload: Protected by automatically resettable fuse

Temperature Drift:

Input	0 to 65° C ambient	-40 to 0° C ambient
Current	±0.20% FS (50 PPM/°C)	±0.80% FS
Voltage	±0.02% FS (1.7 PPM/°C)	±0.06% FS

Temperature Inputs

Inputs: Factory calibrated, field selectable: type J, K, T, or E thermocouples and 100 Ω platinum RTD (0.00385 or 0.00392 curve)

Resolution: 1°; type T TC & RTD: 1° or 0.1°

Cold Junction Reference: Automatic

Temperature Drift: ±2°C maximum

Offset Adjustment: Programmable to ±19.9°. This parameter allows the user to apply an offset value to the temperature being displayed.

Input Impedance: Greater than 100 kΩ

Type	Range	Acc. (0-65°C)	Acc. (-40-0°C)	Resolution
J	-58° to 1382°F -50° to 750°C	±2°F ±1°C	±5°F ±3°C	1°
K	-58° to 2300°F -50° to 1260°C	±2°F ±1°C	±4°F ±2°C	1°
T	-292° to 700°F -180° to 371°C	±2°F ±1°C	±13°F ±7°C	1° or 0.1°
E	-58° to 1700°F -50° to 927°C	±2°F ±1°C	±11°F ±6°C	1°
RTD	-328° to 1382°F -200° to 750°C	±1°F ±1°C	±5°F ±3°C	1° or 0.1°

Relays

Rating: 2 Form C (SPDT); rated 3 A @ 30 VDC or 3 A @ 250 VAC resistive load; 1/14 HP (≈ 50 watts) @ 125/250 VAC for inductive loads such as contactors, solenoids, etc.

Deadband: 0-100% FS, user selectable

High or Low Alarm: User may program any alarm for high or low

Relay Operation:

1. Automatic (non-latching) 2. Latching 3. Pump alternation control

Relay Reset: User selectable via front panel buttons or PC

1. Automatic reset only (non-latching)

2. Automatic plus manual reset at any time (non-latching)

3. Manual reset only, at any time (latching)

4. Manual reset only after alarm condition has cleared (latching)

Automatic Reset: Relays reset when input passes the reset point

Manual Reset: Front panel button, MeterView™, Modbus registers

Time Delay: 0 to 199 seconds, on and off delays; programmable

Sensor Break Relay Operation: The sensor break relay condition may be programmed for each relay as On (alarm) or Off (non-alarm). The relays will enter these states when a sensor break is detected for RTD or thermocouple inputs. These settings have no effect when current or voltage inputs are selected.

Fail-Safe Operation: Programmable, independent for each relay.

Relay coils are energized in non-alarm condition. In case of power failure, relays will go to alarm state.

Auto Initialization: When power is applied to the meter, relays will reflect the state of the input to the meter.

Serial Communications

Compatibility: EIA-232, and EIA-485 with PDA7232 and PDA7422 Trident adapters.

Protocol: Modbus RTU

Meter Address: PDC protocol: 0 to 99, Modbus protocol: 1 to 247

Baud Rate: 300 to 19,200 bps

Transmit Time Delay: Programmable 0 to 199 ms

Data: 8 bit (1 start bit, 1 stop bit)

Parity: None (1 or 2 stop bits), even, or odd (Modbus only; PDC protocol does not use parity)

Turn Around Delay: Less than 2 ms (fixed)

Refer to PDC and Modbus Serial Communications Protocol manuals for details.

Isolated 4-20 mA Transmitter Output

Scaling Range: 1.00 to 23.00 mA; reverse scaling allowed.

Calibration: Factory calibrated 4.00 to 20.00 mA

Accuracy: ±0.1% FS ±0.004 mA

Temperature Drift: 50 PPM/°C

Note: Analog output drift is separate from input drift

Isolation: 500 V input-to-output or output-to-24 VDC supplies; 4 kV output-to-power line. For -6X5 models only: 100 V output-to-24 VDC supply

External Power: 35 VDC maximum

Output Loop Resistance: Loop Resistance

Power Supply	Minimum	Maximum
24 VDC	10 Ω	700 Ω
35 VDC (external)	100 Ω	1200 Ω

PD765 Trident Series Process & Temperature Meters

External Button Contacts (X2 Models Only)

Number: Four

Function: Remote operation of front-panel buttons

Open State: +5 VDC open contact on button input terminals

Closed State: Closed contact button input terminal to common/ground, active low 0 to 0.4 VDC

MOD-LH Light / Horn

Available for these Models: Trident X2 only.

Light Colors: MOD-LH Models: Red, green, yellow, blue or white. MOD-LH5CB1-X2: User selectable: red, green, yellow, blue, or white.

Light Action: Can be wired to flash (not available on MOD-LH5CB1-X2) or stay steady on

Light / Horn & Reset Button Installation: When MOD-LH is ordered with an enclosure, the user performs installation and wiring of Light / Horn and Reset Button in predrilled holes.

Horn: 85 dB

Rating: IP65

Light / Horn Independence: Light and horn can be controlled via separate relays

Power Requirement: No additional power required when wired to a Trident X2 meter. When mounted remote: 24 VDC

Transmitter Power Supply: The Trident X2's internal transmitter power supply is capable of supplying 24 VDC @ 200 mA to power the transmitter and other devices such as the Light / Horn. The following table illustrates how much of this current is required to drive various Light / Horns. If more current is needed, then consider the PDA1024-01.

MOD-LH and MOD-LH5CB1-X2 Models:

Color	Current Required	Color	Current Required
Red	17 mA	Blue	15 mA
Green	15 mA	White	42 mA
Yellow	23 mA	Horn	20 mA

Example: 17 mA (Red Light) + 20 mA (Horn) = 37 mA total current needed from the 200 mA supply. Available current = 163 mA

Reset / Silence Button: NEMA 4X; may be wired to the external button contacts on Trident X2. The Ack front panel button can be used to reset / acknowledge the relays.

Reset Button Labels: The Light / Horn accessory comes with 9 pre-printed message labels the user can affix under the red button: RESET, BATCH, ACK, TARE, SILENCE, STOP, START, PAUSE, START/STOP.

Light / Horn Mounting Connection: M22

Hole Sizes: Light / Horn: 0.875" (22 mm);

Reset Button: 0.630" (16 mm)

Cable Length: 3.28 feet (1 meter)

Operating Temperature Range: -5 to 40°C (23 to 104°F)

ORDERING INFORMATION

Trident X2 PD765 • Large Display Models		
85-265 VAC Model	12-36 VDC Model	Options Installed
PD765-6X0-00	PD765-7X0-00	None
PD765-6X0-10		24 VDC Transmitter Supply
PD765-6X2-00	PD765-7X2-00	2 Relays
PD765-6X2-10		2 Relays + 24 VDC Transmitter Supply
PD765-6X3-00	PD765-7X3-00	4-20 mA Output
PD765-6X3-10		4-20 mA Out + 24 VDC Transmitter Supply
PD765-6X3-20		4-20 mA Out + Dual 24 VDC Transmitter Supplies
	PD765-7X5-00	2 Relays + 4-20 mA Output
PD765-6X5-10		2 Relays + 4-20 mA Output + 24 VDC Transmitter Supply

Trident PD765 • Standard Display Models		
85-265 VAC Model	12-36 VDC Model	Options Installed
PD765-6R0-00	PD765-7R0-00	None
PD765-6R0-10		24 VDC Transmitter Supply
PD765-6R2-00	PD765-7R2-00	2 Relays
PD765-6R2-10		2 Relays + 24 VDC Transmitter Supply
PD765-6R3-00	PD765-7R3-00	4-20 mA Output
PD765-6R3-10		4-20 mA Out + 24 VDC Transmitter Supply
PD765-6R3-20		4-20 mA Out + Dual 24 VDC Transmitter Supplies
	PD765-7R5-00	2 Relays + 4-20 mA Output
PD765-6R5-10		2 Relays + 4-20 mA Output + 24 VDC Transmitter Supply

Accessories	
Model	Description
PDA1024-01	24 VDC Power Supply for DIN Rail
PDA7420	Trident Meter Copy Cable, 7' (2.1 m)
PDA7422	Trident RS-485 Serial Adapter
PDA7232	Trident RS-232 Serial Adapter
PDA7485-I	RS-232 to RS-422/485 Isolated Converter
PDA8006	USB Serial Adapter for Programming Meter with MeterView Software
PDA8232-N	USB to RS-232 Non-Isolated Converter
PDA8485-I	USB to RS-422/485 Isolated Converter
PDX6901	Suppressor (snubber): 0.01 µF/470 Ω, 250 VAC

PD765 Trident Series Process & Temperature Meters

ORDERING INFORMATION (continued)



Light / Horn Accessories for Trident	
Model	Description
MOD-LHRB1	Red Light / Horn and Reset Button with Holes Drilled in Enclosure ⁽¹⁾
MOD-LHGB1	Green Light / Horn and Reset Button with Holes Drilled in Enclosure ⁽¹⁾
MOD-LHYB1	Yellow Light / Horn and Reset Button with Holes Drilled in Enclosure ⁽¹⁾
MOD-LHBB1	Blue Light / Horn and Reset Button with Holes Drilled in Enclosure ⁽¹⁾
MOD-LHWB1	White Light / Horn and Reset Button with Holes Drilled in Enclosure ⁽¹⁾
MOD-LH5CB1	Light / Horn with User Choice of Red, Green, Yellow, Blue or White Light, Reset Button, and Holes Drilled in Enclosure ⁽¹⁾
PDA-BUTTON1R	Red Reset Button
PDA-BUTTON1G	Green Reset Button
PDA-BUTTON1B	Blue Reset Button
PDA-LHR	Red Light / Horn
PDA-LHG	Green Light / Horn
PDA-LHY	Yellow Light / Horn
PDA-LHB	Blue Light / Horn
PDA-LHW	White Light / Horn
PDA-LH5C	Light / Horn with User Choice of Red, Green, Yellow, Blue or White Light
PDA-LHW	White Light / Horn

Notes

- This MOD supplies the Light / Horn and Reset Button. The enclosure comes pre-drilled with holes for Light / Horn and Reset Button and the user performs the installation and wiring. Meter and enclosure are sold separately. The Light / Horn hole is in the back left corner of the enclosure and the Reset Button is centered on the cover of the enclosure below the meter about an inch off the bottom of the cover except on the PDA3400 series where it is mounted on the side of the enclosure.
- Specify PDA-LH model to order the Light / Horn to be mounted by the user in user-drilled hole.
- Specify PDA-BUTTON model to order Reset Button to be mounted by the user in user-drilled hole.



PDA2360 Series Control Stations	
Model	Description
PDA2360-E	Emergency Stop Button
PDA2361-A	1 Black Ack Button
PDA2361-Q	1 Black Silence Button
PDA2364-MRUE	4 Black Buttons: Menu, Right, Up, Enter



Signal Splitter and Conditioner Accessories	
Model	Description
PD659-1MA-1MA	Signal Isolator with One 4-20 mA Input and One 4-20 mA Output
PD659-1MA-2MA	Signal Splitter with One 4-20 mA Input and Two 4-20 mA Outputs
PD659-1V-1MA	Signal Conditioner with One 0-10 VDC Input and One 4-20 mA Output
PD659-1MA-1V	Signal Conditioner with One 4-20 mA Input and One 0-10 VDC Output

Disclaimer

The information contained in this document is subject to change without notice. Precision Digital Corporation makes no representations or warranties with respect to the contents hereof, and specifically disclaims any implied warranties of merchantability or fitness for a particular purpose. See Warranty Information and Terms & Conditions on www.predig.com for complete details. ©2006-2019 Precision Digital Corporation. All rights reserved.



WARNING

Cancer and Reproductive Harm - www.P65Warnings.ca.gov

LDS765_P 02/20

PRECISION DIGITAL CORPORATION

Authorised Distributor:



**NATIONWIDE
OIL & GAS**

46, Jalan SS 22/21, Damansara Jaya,
47400 Petaling Jaya,
Selangor Darul Ehsan, Malaysia.

Email: nog@nog.com.my

Web access: <http://www.nog.com.my>

**PRECISION
DIGITAL**
www.predig.com