

# PD6080/PD6081 PROVu® Super Snooper Modbus® Scanners



**PROVu®**  
SERIES

**SUPER-BRIGHT LEDs**  
Our Brightest Display Ever 

**SCANVIEW**  
USB Install 

Super Snooper 

**Modbus**

**MODBUS**  
SCANNERS



- Modbus® RS-485 RTU Serial Communications as Master, Slave, or Snooper
- RS-485 Serial Communications Standard
- Decimal or Feet & Inches (with Eighths & Sixteenths) Display Options
- Scan up to 16 Modbus Process Variables
- Dual Analog Inputs (0-20 mA, 4-20 mA, 0-5 V, 1-5 V, and  $\pm 10$  V)
- Addition, Difference, Average, Multiplication, Division, Min, Max, Weighted Average, Ratio, Concentration, & More
- Large Dual-Line 6-Digit Display, 0.60" & 0.46"
- Optional SunBright Display Models for Outdoor Applications
- NEMA 4X, IP65 Front
- Input Power Options Include 85-265 VAC or 12-24 VDC
- Isolated 24 VDC @ 200 mA Transmitter Power Supply
- Programmable Display & Function Keys
- 32-Point, Square Root, or Exponential Linearization
- Multi-Pump Alternation Control
- 2 or 4 Relays + Isolated 4-20 mA Output Options
- External 4-Relay & Digital I/O Expansion Modules
- Onboard USB and ScanView Programming Software

**PRECISION  
DIGITAL**   
[www.predig.com](http://www.predig.com)

**PRECISION DIGITAL CORPORATION**

# PD6080/PD6081 PROVu® Super Snooper Modbus® Scanners



UV Resistant  
Sunlight Readable



Front Panel  
NEMA 4X Rated



Large  
0.6" Digits

PD6081

Rugged Front

Dual-Line  
6-Character  
Display

User Configurable  
Display (Showing  
custom tag)

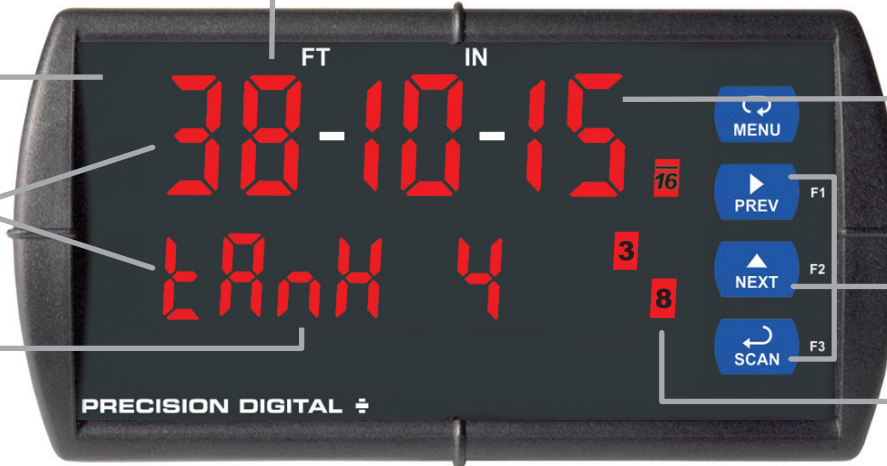

User Configurable  
Display (Showing Feet  
& Inches to nearest  
16th of an inch)

Programmable  
Function Keys

Alarm  
Status Indicators

## TAKE ADVANTAGE OF YOUR MODBUS ENABLED TRANSMITTERS

By using the Modbus signal from your existing multivariable transmitters, you will open up a whole new dimension of display possibilities. Paired with a new Precision Digital Modbus Scanner, you can display multiple variables including level, interface level, density, temperature, and more.

The PD6080/PD6081 Super Snooper Modbus Scanners are multi-purpose, easy-to-use scanners that can be programmed as Modbus RTU Masters, Slaves, or Snoopers. They are capable of scanning up to 16 process variables (PVs), which make them ideal for multiple tank level monitoring and control. Plus, they combine two independently programmed analog inputs with powerful math functions. Various math functions that may be applied to the inputs and PVs include addition, difference, average, multiplication, division, ratio, and more.

## KEY FEATURES

The PROVu PD6080/PD6081 can be programmed as a Modbus RTU Master, Slave, or Snooper. Its Modbus communications capabilities, two process input channels, and math functions make it unique, while still maintaining the great features and quality of the PROVu family.

## Modbus RTU Serial Communications

As a Master, the PROVu PD6080/PD6081 reads up to 16 slave devices, scales the data from each, and displays each on an alternating display. In Master Mode it is capable of polling up to 16 process variables (PVs). It displays each PV (PV1-PV16) alternately on the top and/or bottom display.

In Snooper Mode, the PD6080/PD6081 is able to read any of the variables being polled by the master by listening to the bus traffic. It picks up specific register or registers being polled by a master device from a specific slave device and processes the data being read. No other device on the Modbus network needs to be reprogrammed for the Snooper Mode PD6080/PD6081 to display data polled by the Modbus master.

As a Slave, the PD6080/PD6081 is controlled by a master device. The data sent to it by the master is scaled, displayed, and used to operate the internal relays and 4-20 mA output.

## Standard LED and Optional SunBright LED Display Models

The PROVu's standard and SunBright display models feature extraordinarily bright LED displays. They are perfect for indoor and outdoor applications where visibility may be impaired by smoke, fog, dust, or distance. The intensity on the SunBright display model is so high it can be read even in the brightest sunlight.

## Function Keys

There are three function keys available to the user. These keys can be programmed to trigger certain events (i.e. acknowledge alarms, reset max and/or min, disable/enable output relays, or hold current relay states), provide direct menu access points, and more.

Learn more about using the PROVu's Function Keys by watching a video at [predig.com/videos](http://predig.com/videos)

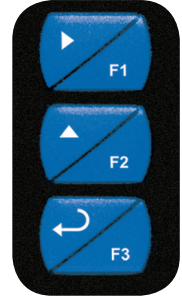

## Free USB Programming Software & Cable

The PROVu® comes preloaded with free ScanView programming software that connects and installs directly to your PC with a standard USB cable, also provided free with each instrument. This eliminates the need to insert CDs, install drivers, or download software from the internet. The software will allow you to configure, monitor, and datalog a PROVu® PD6080/81 using your PC. Just simply connect the meter to your PC with the USB cable and within minutes you will be programming it.



## Modbus Application Capabilities

The PD6080 & PD6081 scanners can communicate with any Modbus device using the ever-popular Modbus communications protocol. Take advantage of the Modbus capabilities in the level and flow transmitters you already have by using Master Mode to read more data, more accurately. Possible applications include:

- Use Master Mode to scan the top level, interface level, and temperature from Modbus multivariable level transmitters.
- Use Master Mode to display the flow rate, tag, and units, for multiple Modbus-enabled flow meters.
- Use Snooper Mode to add a tank side indicator at eye-level for a Modbus level transmitter being polled by a master in the control room.
- Use Snooper Mode to add additional remote displays to a network with a Modbus scanner acting as the master, and display the data at all operator locations.
- Use Slave Mode to display data sent to the scanner by a Modbus master in the control room.

These are just a few capabilities of using the PD6080 & PD6081 Modbus Scanners in a Modbus process network.

## Powerful Math Functions

The PD6080/81 uses up to 16 process variables in a variety of powerful math functions designed for process applications. Programmable Adder (P) and Factor (F) constants allow each formula to be customized as needed for a specific application. The Math Channels (C1-C4) may be displayed in many useful combinations. Most math functions may be applied to all PVs: for example, it is possible to add up to 16 PVs and calculate the total volume of all the tanks in a field. The Math2 function allows for further calculations on the results of other math channels (e.g. C4= C2/C1).

Name	Function	Setting
Addition	$C1=(PV1+PV2+P)*F$	5000
Difference	$C1=(PV1-PV2+P)*F$	d iF
Absolute Difference	$C1=((Abs(PV1- PV2)+P)*F$	d iFRb5
Average	$C1=(((PV1+PV2)/2)+P)*F$	AVG
Multiplication	$C1=((PV1*PV2)+P)*F$	000001
Division	$C1=((PV1/PV2)+P)*F$	d iU dE
Maximum PV	Maximum value of all selected PVs	H i-PU
Minimum PV	Minimum value of all selected PVs	Lo-PU
Draw	$C1=((PV1/PV2)-1)*F$	d rPU
Weighted Average	$C1=((PV2-PV1)*F)+PV1$	W AVG
Ratio	$C1=(PV1/PV2)*F$	rRt i0
Concentration	$C1=(PV1/(PV1+PV2))*F$	ConcEn
Resultant Math Channel	Math on all other math channels	000002
Addition	$C3=(C1+C2+P)*F$	5000
Difference	$C4=(C1-C2+P)*F$	d iF
Absolute Difference	$C3=((Abs(C1- C2)+P)*F$	d iFRb5
Average	$C4=(((C1+C2)/2)+P)*F$	AVG
Multiplication	$C3=((C1*C2)+P)*F$	000001
Division	$C4=((C1/C2)+P)*F$	d iU dE

Note: The F constant can be any value from 0.00001 to 999999. If the value is less than 1, it will have the same effect as a divider. For example, the average could also be derived by using  $(A+B)*F$ , where  $F = 0.500$ .

## Customizable Displays

The PROVu has two red LED displays, an Upper display 0.60" (15 mm) high, and a Lower display 0.46" (12 mm) high. Each display is a full 6 digits (-99999 to 999999). The display assignment is programmable, allowing for various one line or two line PV configurations.



Alternating Tag and Units on the Bottom Display for Each PV



Displaying Two PVs

## Custom Tag and Units for Each PV

Each process variable has an independently programmable tag and unit name. The tag must display on the line opposite the PV or alternate with the PV during scanning. The unit may be configured to display similarly. The tag and unit may be programmed as any six-digit alphanumeric value.

## Automatic or Manual Scanning

The scanner may automatically or manually cycle through the PVs. The scanner can be programmed to display each PV for 1 to 99.9 seconds. The NEXT and PREV buttons can be used to manually scan to the next or previous PV display. The SCAN button will pause and resume automatic scanning.



## Rugged

A unique front panel design makes the PROVu nearly impenetrable in typical applications. Here, the PROVu easily survives a direct hit on the display from a heavy 2" solid stainless steel ball dropped from a height of eight feet (approximately 2.4 meters).

## Three Tier Password Protection

The PROVu PD6080/81 offers 3 levels of password protection:

- Level 1 protection allows the operator use of only the 3 pre-configured function keys on the front panel without a password.
- Level 2 protection allows the operator use of only the function keys and the ability to change set points without a password.
- Level 3 protection restricts the operator from using the function keys and all meter configuration menus without a password.

## Advanced Linearization Capability

The PROVu PD6080/81 includes a 32-point linearizer for PV1 & PV2 (all other PVs utilize two-point linearization). In non-linear level applications (i.e. some pumping or lift stations), it can easily compensate for submerged equipment or plumbing that displace usable volume. In addition to the 32-point linearization, the PROVu can perform a square root or programmable exponent function on one or both analog inputs, Modbus inputs, any or all enabled PVs, or automatically calculate level in round horizontal tanks by inputting the length and height of the tank. Each input's linearization is performed independently prior to the input value being used in any math function.

## Typical Modbus Application Example

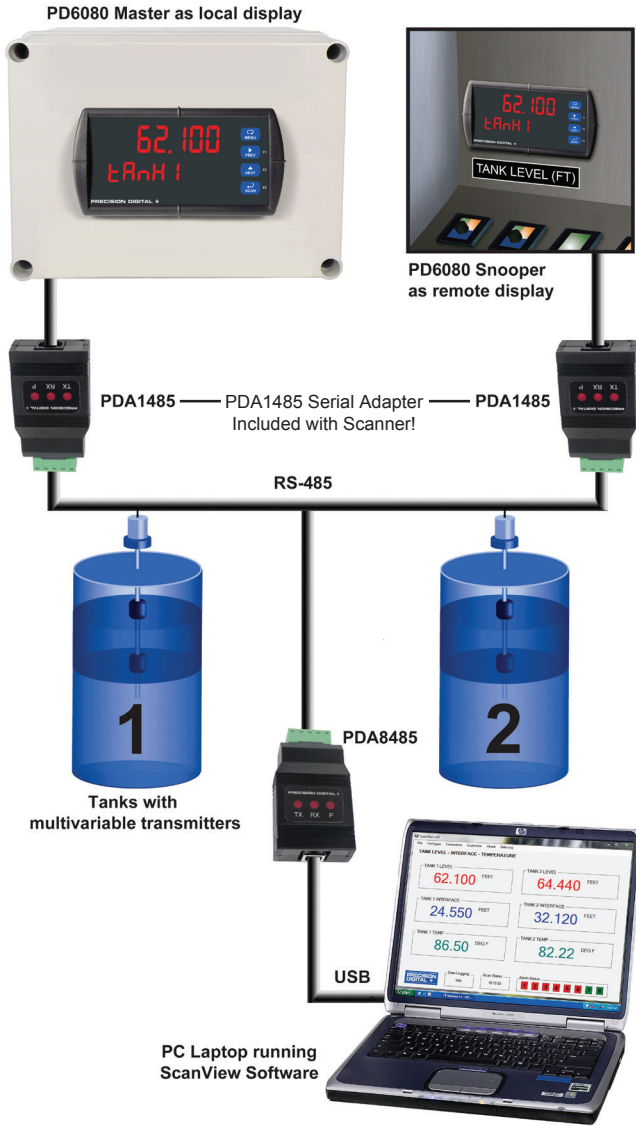

## Dual Analog Input Scanning

The PD6080/81 has two process input channels (A & B) capable of accepting current (0-20, 4-20 mA) and voltage ( $\pm 10$ , 0-5, 1-5, 0-10 VDC). Each input is programmed separately, with independent input type selection and scaling. These inputs may be displayed individually as part of the customizable dual-line display, or used with a wide range of math functions. Each input has a custom unit or tag that may be displayed. A 24 V transmitter power supply is standard and may be used to power the inputs.

Each analog input enabled counts toward the available 16 PVs that may be scanned. The scanner could be configured to scan a maximum of 14 Modbus PVs, 4 math channels, and both analog inputs.

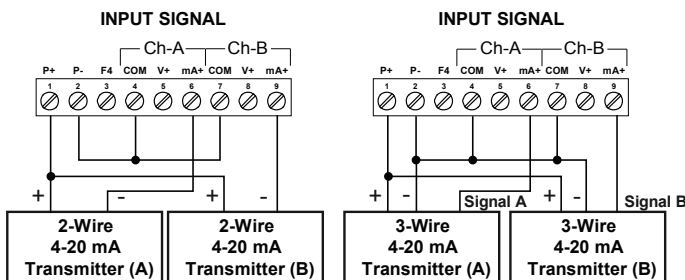

## On-Board Digital Input

The PD6080/81 includes a digital input as a standard feature. This digital input can operate with the interlock relays feature, force relays on from a signal from a PLC or relay on other equipment, acknowledge alarms, and much more. This is ideal for installations where the meter is inaccessible behind a cover, or where an additional function key is needed for customized operation.

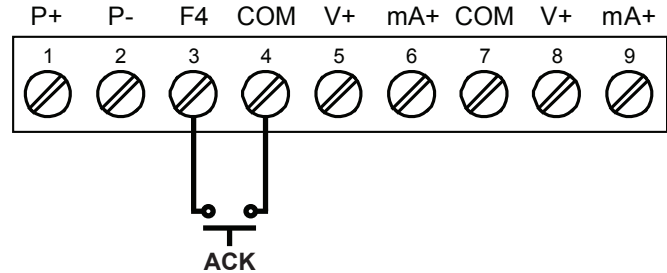

## DIGITAL COMMUNICATIONS

### RS-485 Serial Communications Standard

The PD6080/81 includes an RS-485 serial communications module, PDA1485. This may be wired for full-duplex, 5-wire RS-485, or half-duplex 3-wire RS-485. A variety of serial adapters are available for other communications protocols at [www.predig.com](http://www.predig.com).

### ScanView Software

Precision Digital's free ScanView PC-based software allows the operator to easily configure, monitor, and datalog a PROVu PD6080/81 from a PC (available for download at [www.predig.com](http://www.predig.com)) with a serial adapter. The software can save this data to the scanner and/or PC. ScanView greatly simplifies the construction of the linearization tables and gives operators another level of control. ScanView installation is required for tech support.

## FIELD EXPANSION MODULES

Add functionality to the PROVu in the field with easy-to-install external expansion modules. The menu items for these modules do not appear until the module is connected, simplifying the menu.

### PDA1044 I/O Expansion Module

Four digital inputs and four digital outputs are available per expansion module. The PROVu will accept two of these modules. External digital inputs can function similarly to the front panel function keys or on-board digital input F4. They can be configured to trigger certain events (i.e. acknowledge/reset alarms, reset max and/or min values, disable/enable all output relays, and hold current relay states), provide direct menu access point, or mimic front panel keys. Digital outputs can be used to remotely monitor PROVu's alarm relay output states, or the states of a variety of actions and functions executed by the scanner.

### PDA1011 Dual Analog Output Module

Two additional isolated analog outputs may be added to the PROVu. These analog outputs have the same features and functions of the on-board analog output option. Each passive output requires an isolated external DC supply.

### PDA1004 Relay Expansion Module

An external module containing four 3 A Form A (SPST) relays can be added to the PROVu at any time and performs identically to the on-board relays.

## OUTPUTS

Each output of the PD6080/81 may be assigned to a single analog input, Modbus PV, or math PV. The output will reflect the state of that assigned variable at all times during scanning.

### Relay Outputs

The PROVu has up to four 3 A Form C relays (SPDT) with multiple power loss fail-safe options. Relays can be configured for proper protective action upon input loop break. Relay ON and OFF delay times are user adjustable. Up to eight front panel indicators show alarm and/or relay state. All relays can be configured for 0-100% deadband.

### Relay Operation/Configuration

There are powerful relay functions that can be configured in the PROVu PD6080/81, including:

- Automatic reset only (non-latching)
- Automatic + manual reset at any time (non-latching)
- Latching (manual reset only)
- Latching with clear (manual reset only after alarm condition has cleared)
- Pump alternation control (automatic reset only)
- Sampling (activated for a user-specified time)
- User selectable fail-safe operation
- Relay action for loss (break) of 4-20 mA input signal
- Time delay (on and off), independent for each relay
- Manual control mode
- Interlock relay mode

### Analog Output

The isolated analog retransmission signal scales for any 4 mA and 20 mA display value. While the output is nominally 4-20 mA, the signal will accurately accommodate under- and over-ranges from 1 to 23 mA.

### Manual Output Control

Take control of any output with this feature. All relays can be forced ON or OFF, and the 4-20 mA output signal can be set to any value within its range. When the relays and 4-20 mA output are controlled manually, an LED labeled "M" is turned on and the associated Alarm LEDs (1-8) flash every 10 seconds indicating that the meter is in manual control mode.



### Isolated Transmitter Power Supply

A powerful 24 V @ 200 mA power supply is a standard feature on the PROVu PD6080/81. It can be configured for 5, 10, or 24 V (default) by means of a simple internal jumper (see manual). An additional power supply (24 V @ 40 mA) is standard with the 4-20 mA output option.

### Sampling Function (PV Triggered Timed Relay)

The sampling function allows the operator to set a set point for a "sampling" relay. When the PV reaches that set point, it will close that relay's contacts for a preset period of time (0.1 to 5999.9 seconds). An example of its use may be for beer/ale fermentation. When the batch reaches a certain pH, the relay contacts would close and alert someone or automatically take a sample of the batch. This function can be used whenever a timed relay output closure is required when the PV reaches a certain set point.

### Interlock Relay(s)

This function allows a process to use one or more very low voltage input signals or simple switch contacts to control the state of one or more internal "interlock" relays. A violation (i.e. loss of input, open switch, or open circuit) forces one or more N/O interlock relay contacts to open. One input can be used in series with a number of interlock switches, or up to eight inputs can be required to force-on one (or more) internal interlock relays. Please see Application Note AN-1008 on our website for more information. Requires PDA1044 Digital I/O module or use of on-board digital input F4.

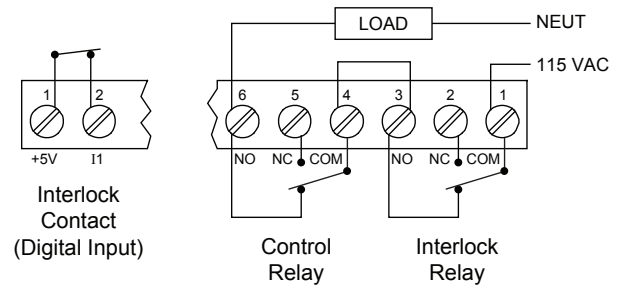

## SIGNAL INPUT CONDITIONING

Non-linear input signals (i.e. weirs & flumes, differential pressure, etc.) can be linearized with the PROVu's simple to use built-in signal input conditioning, such as: square-root extractor, exponential linearizer, round horizontal tank linearizer, or the PROVu powerful general purpose 32-point linearizer (32 point for for PV1 & PV2 only - all other PVs use two linearization points).

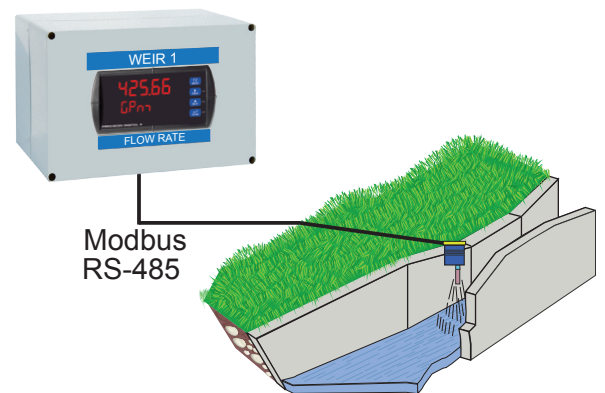

Weir Flow Calculated Using Exponential Signal Input Conditioning

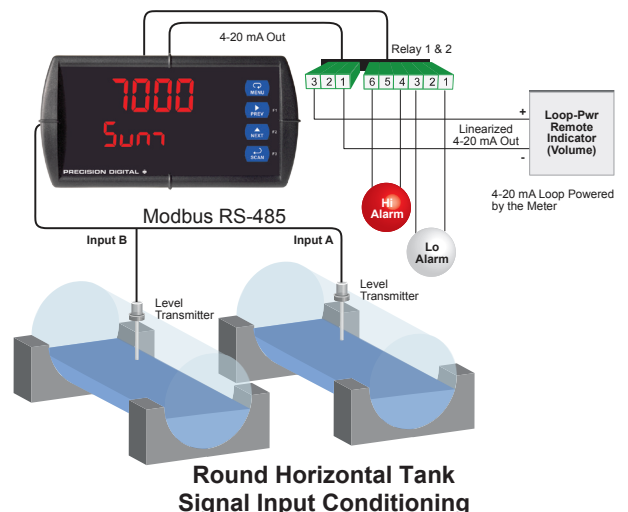

Round Horizontal Tank Signal Input Conditioning

# PD6080/PD6081 ProVu® Super Snooper Modbus® Scanners

## NEMA 4 & 4X FIELD ENCLOSURES

Precision Digital offers a variety of rugged enclosures that provide a high degree of protection against harsh operating environments. Thermoplastic and stainless steel NEMA 4X, and painted steel NEMA 4 enclosures for up to 10 ProVu meters are available.



**PDA2811** Plastic Low-Cost    **PDA2302** Plastic Economical    **PDA2604** Stainless Steel

See our complete offering at [www.predig.com/esu](http://www.predig.com/esu)

## DIMENSIONS

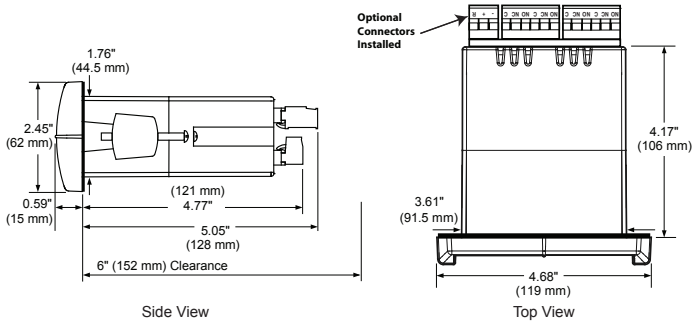

### Notes:

1. Panel cutout required: 1.772" x 3.622" (45 mm x 92 mm)
2. Panel thickness: 0.040 - 0.250" (1.0 mm - 6.4 mm)
3. Mounting brackets lock in place for easy mounting
4. Clearance: Allow 6" (152 mm) behind the panel

## CONNECTIONS

- Form C (SPDT) relays
- Two isolated supplies available even on 12/24 VDC input power models
- Removable terminal blocks
- 2 or 4 relays + isolated 4-20 mA output option

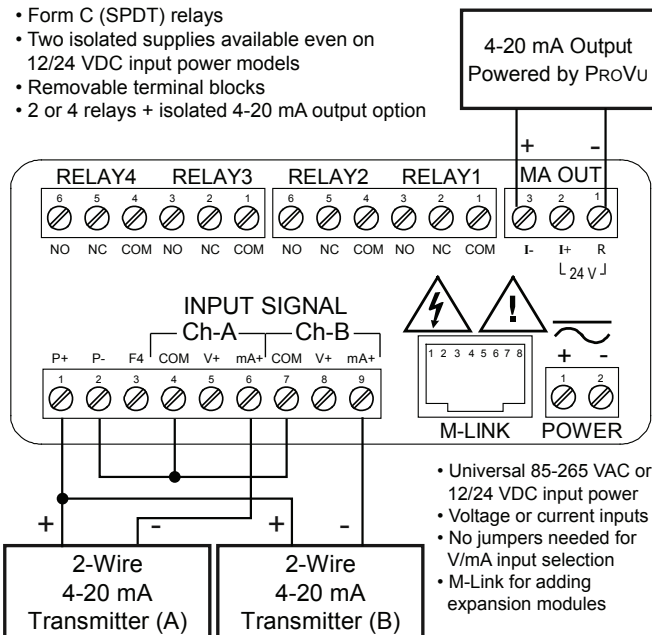

- Universal 85-265 VAC or 12/24 VDC input power
- Voltage or current inputs
- No jumpers needed for V/mA input selection
- M-Link for adding expansion modules

## SPECIFICATIONS

Except where noted all specifications apply to operation at +25°C.

### General

**Input/Output:** Modbus RTU over RS-485, Two analog inputs (4-20 mA, ±10 V)  
**Display:** Upper display: 0.60" (15 mm) high. Lower display: 0.46" (12 mm) high. Both are 6 digits (-99999 to 999999), red LEDs

**Display Intensity:** Eight user selectable intensity levels

**Display Scan Rate:** Master/Snooper: 1/second to once every 99.9 seconds. Slave: Dependent on master device (e.g. PLC)

**Overrange:** Display flashes 999999

**Underrange:** Display flashes -999999

**Display Assignment:** The top display may be assigned to PV (process values), Ch C (math channel), PV & units, tag & PV, tag-PV-units, C & units, tag-C-unit, Set point 1-8, max/min PV, max/min C. The bottom display may be assigned to all of the above, tag, or off. The tag and units are displayed alternately for 2 sec, when selected. Different tags & PVs may be selected to display on the top and bottom displays at the same time.

**Front Panel:** NEMA 4X, IP65

**Programming Methods:** Four front panel buttons, digital inputs, PC and ScanView software, Modbus registers, or cloning using Copy function.

**F4 Digital Input Contacts:** 3.3 VDC on contact. Connect normally open contacts across F4 to COM.

**F4 Digital Input Logic Levels:** Logic High: 3 to 5 VDC

**Noise filter:** Programmable from 2 to 199 (0 will disable filter)

**Filter Bypass:** Programmable from 0.1 to 99.9% of calibrated span

**Recalibration:** All ranges are calibrated at the factory. Recalibration is recommended at least every 12 months.

**Max/Min Display:** Max (Peak) / min (Valley) readings reached by the process are stored until reset by the user or until power to the meter is cycled.

**Password:** Three programmable passwords restrict modification of programmed settings.

**Non-Volatile Memory:** All programmed settings are stored in non-volatile memory for a minimum of ten years if power is lost.

**Power Options:** 85-265 VAC 50/60 Hz, 90-265 VDC, 20 W max, or optional model with 12/24 VDC ±10%, 15 W max.

**Fuse:** Required external fuse: UL Recognized, 5 A max, slow blow; up to 6 meters may share one 5 A fuse.

**Isolated Transmitter Power Supply:** Terminals P+ & P-: 24 VDC ± 10%. Internally selectable jumper for 24, 10, or 5 VDC supply.

85-265 VAC models rated @ 200 mA max, 12/24 VDC powered models rated @ 100 mA max, @ 50 mA max for 5 or 10 VDC supply.

**Normal Mode Rejection:** Greater than 60 dB at 50/60 Hz

**Isolation:** 4 kV input/output-to-power line. 500 V input-to-output or output-to-P+ supply.

**Overvoltage Category:** Installation Overvoltage Category II: Local level with smaller transient overvoltages than Installation Overvoltage Category III.

**Environmental:** Operating temperature range: -40 to 65°C

Storage temperature range: -40 to 85°C

Relative humidity: 0 to 90% non-condensing

**Connections:** Removable screw terminal blocks accept 12 to 22 AWG wire, RJ45 for external relays, digital I/O, and serial communication adapters.

**Enclosure:** 1/8 DIN, high impact plastic, UL 94V-0, color: black

**Mounting:** 1/8 DIN panel cutout required: 3.622" x 1.772" (92 mm x 45 mm). Two panel mounting bracket assemblies are provided.

**Tightening Torque:** Screw terminal connectors: 5 lb-in (0.56 Nm)

**Overall Dimensions:** 4.68" x 2.45" x 5.64"

(119 mm x 62 mm x 143 mm) (W x H x D)

**Weight:** 9.5 oz (269 g)

**UL File Number:** UL & c-UL Listed. E160849; 508 Industrial Control Equipment.

**Warranty:** 3 years parts & labor

**USB Connection:** Compatibility: USB 2.0 Standard, Compliant

Connector Type: Micro-B receptacle

Cable: USB A Male to Micro-B Cable

Driver: Windows 98/SE, ME, 2000, Server 2003/2008, XP 32/64-Bit,

Vista 32/64-Bit, Windows 7 32/64-Bit, Windows 10 32/64-Bit

Power: USB Port

## Modbus Serial Communications

**Protocol:** Modbus RTU

**Meter Address/Scanner ID:** 1 - 247, 256-259 (for Volts and mA).

**Baud Rate:** 300 - 19,200 bps

**Transmit Time Delay:** Programmable between 0 and 199 ms

**Data:** 8 bit (1 start bit, 1 or 2 stop bits)

**Parity:** Even, odd, or none with 1 or 2 stop bits

**Byte-to-Byte Timeout:** 0.01 - 2.54 seconds

**Turn Around Delay:** Less than 2 ms (fixed)

**Operating Modes:** MASTER: Processes data read from Modbus RTU slave devices. It polls up to 16 process variables from 1 to 16 slave devices. The Master is capable of scanning the selected PVs, scale the data, trigger relays, perform math operations, and drive the analog outputs. SNOOPER: Listens to the Modbus traffic and picks up a specific register or registers being polled by a master device from a specific slave device and processes the data being read. The Snooper mode handles the data the same way as the Master.

SLAVE: Processes data sent to it from a Modbus RTU master device.

**PV Number:** PV1–PV16 Enable or disable the process variables to be polled by the Master.

**Slave ID:** Assign the slave ID or address (1-247, 256-259 for mA or volts inputs) containing the process variables to be displayed by the selected PV.

**Function Code:** Select which Modbus function code (03, 04, or 65) to use in reading the slave device.

**Register Number:** 5 digit: 30001-39999, 40001-49999, or 1-65,536  
6 digit: 300001-365536 or 400001-465536 (Function Code 65 N/A here)  
Specifies which register(s) to read in the slave device. Range is dependent on Function Code selection (65, 04, or 03) and digits selection (5 or 6).

**Data Type:** Select the data format that the slave device uses. Select between Short integer (2 byte), Long integer (4 byte), or floating point (4 byte), Signed or Unsigned (integer only) and byte order: 1234, 4321, 2143, or 3412 (big-endian vs. little-endian, or swapped).

**Poll Time:** 1.0 to 99.9 sec. Time between read-commands (Master mode).

**Slave Response Timeout:** 0.0 to 99.9 seconds: Time allowed for the slave to respond before the scanner generates a communication break condition. The master polls the slave 3 times before starting the response timeout timer. Slave/Snooper mode: Time the scanner will wait for new data before going into break condition. Slave mode: Programming 0 disables the timeout; the last value received will be displayed indefinitely.

**Communication Breakdown:** Displays “b-r-E-R-H” after the Master has polled the slave device 3 times and the response timeout has elapsed. The Snooper and Slave modes go into break condition after no new data is received within the response timeout window. Relays can be programmed to go on, off, or ignore the break condition. The analog outputs can be set up to generate a fixed mA current when a break condition is detected.

**Programmable Constants:** Constant P (Adder): -99999 to 999999, default: 0.000; Constant F (Factor): 0.00001 to 999999, default: 1.000

**Math Functions:** Addition, difference, absolute difference, average, multiplication, division, max of A or B, min of A or B, draw, weighted average, ratio, concentration. See instruction manual for details.

**Tag & Units:** 6-character, independent tag and units for each PV and math channel.

**PV Format:** PD6080 default: Decimal format. PD6081 default: FT & IN, 1/8th or 1/16th; decimal format may be selected for bottom display indication.

**Display Decimal Point:** Up to five decimal places or none: *d.ddddd, dd.dddd, ddd.d, dddd.d, dddd.d, or dddddd*

**Float Decimal Point:** Select the number of decimals to use for the floating point data expected from the slave or master device (this is independent from the display decimal point selection).

**PV & Math Scaling:** All PVs and math channels may be scaled to represent the input data in any engineering unit.

Example: Level transmitter = 999.999 inches; to display in Ft-In-1/16th scale input 2 to display 83 Ft – 4 In – 0/16th.

**Scan Mode:** Automatic: 1.0 to 99.9 seconds.

Manual: Front panel or digital inputs

Go on alarm: Continues scanning after an alarm is detected

Stop on alarm: Goes to the alarmed PV and stops scanning; press Scan to resume scanning.

Note: Refer to the PROVu® Modbus Register Tables located at [www.predig.com](http://www.predig.com) for details.

## Relays

**Rating:** 2 or 4 SPDT (Form C) internal and/or 4 SPST (Form A) external; rated 3 A @ 30 VDC and 125/250 VAC resistive load; 1/14 HP (≈ 50 W) @ 125/250 VAC for inductive loads.

**Noise Suppression:** Noise suppression is recommended for each relay contact switching inductive loads.

**Electrical Noise Suppression:** A suppressor (snubber) should be connected to each relay contact switching inductive loads to prevent disruption to the microprocessor's operation. Recommended suppressor value: 0.01 μF/470 Ω, 250 VAC (PDX6901).

**Deadband:** 0-100% of span, user programmable

**High or Low Alarm:** User may program any alarm for high or low trip point. Unused alarm LEDs and relays may be disabled (turned off).

**Relay Operation:** automatic (non-latching), latching (requires manual acknowledgment), sampling (based on time), pump alternation control (2 to 8 relays), Off (disable unused relays and enable interlock feature, manual on/off control mode).

**Relay Reset:** User selectable via front panel buttons, digital inputs, or PC.

1. Automatic reset only (non-latching), when input passes the reset point.
2. Automatic + manual reset at any time (non-latching).
3. Manual reset only, at any time (latching).
4. Manual reset only after alarm condition has cleared (latching).

**Time Delay:** 0 to 999.9 seconds, on & off relay time delays.

Programmable and independent for each relay.

**Fail-Safe Operation:** Programmable and independent for each relay.

**Auto Initialization:** When power is applied to the scanner, relays will reflect the state of the input to the scanner.

## Isolated 4-20 mA Transmitter Output

**Output Source:** Process Variable 1-16, math channels C1-C4, set points 1-8, or manual control mode

**Scaling Range:** 1.000 to 23.000 mA for any display range

**Calibration:** Factory calibrated: 4.000 to 20.000 = 4-20 mA output

**Analog Output Programming:** 23.000 mA maximum for all parameters: Overrange, underrange, max, min, and break

**Communications Break:** Programmable mA output when a slave device does not reply within the response timeout

**Accuracy:** ± 0.1% of span ± 0.004 mA

**Temperature Drift:** 0.4 μA/°C max from 0 to 65°C ambient, 0.8 μA/°C max from -40 to 0°C ambient

**Isolated Transmitter Power Supply:** Terminals I+ & R: 24 VDC ± 10%  
May be used to power the 4-20 mA output or other devices.  
All models rated @ 40 mA max.

**External Loop Power Supply:** 35 VDC maximum

**Output Loop Resistance:**

Power supply	Minimum	Maximum
24 VDC	10 Ω	700 Ω
35 VDC (external)	100 Ω	1200 Ω

## Dual Process Input

**Two Inputs:** Two analog inputs, each separately field selectable:

0-20 mA, 4-20 mA; ±10 V (0-5, 1-5, 0-10 V)

**PV Analog Channel ID:** Ch-A mA: Assign PV to ID 256 or Ch-A volt: 257; Ch-B mA: Assign PV to ID 258 or Ch-B volt: 259

**Accuracy:** ±0.03% of calibrated span ±1 count, square root & programmable exponent accuracy range: 10-100% of calibrated span

**Temperature Drift:** 0.005% of calibrated span/±C max from 0 to 65°C ambient, 0.01% of calibrated span/°C max from -40 to 0°C ambient

**Signal Input Conditioning:** Linear, square root, programmable exponent, or round horizontal tank volume calculation

**Multi-Point Linearization:** 2 to 32 points for PV1 and PV2

**Programmable Exponent:** 1.0001 to 2.9999

**Low-Flow Cutoff:** 0-999999 (0 disables cutoff function) for PV1 and PV2

**Input Impedance:** Voltage ranges: greater than 500 kΩ

Current ranges: 50 - 100 Ω (depending on resettable fuse impedance)

**Input Overload:** Current input protected by resettable fuse, 30 VDC max. Fuse resets automatically after fault is removed.

Calibration Range: Input Range	Minimum Span Input 1 & Input 2
10 Ω	700 Ω
100 Ω	1200 Ω

# PD6080/PD6081 ProVu® Super Snooper Modbus® Scanners

## ORDERING INFORMATION

ProVu® PD6080 Decimal Modbus Scanner Models		
85-265 VAC Model	12/24 VDC Model	Options Installed
PD6080-6H0	PD6080-7H0	None
PD6080-6H2	PD6080-7H2	2 Relays
PD6080-6H3	PD6080-7H3	4-20 mA Output
PD6080-6H4	PD6080-7H4	4 Relays
PD6080-6H5	PD6080-7H5	2 Relays & 4-20 mA Output
PD6080-6H7	PD6080-7H7	4 Relays & 4-20 mA Output

Note: 24 V Transmitter power supply standard on all models.

ProVu® PD6081 Feet & Inches Modbus Scanner Models		
85-265 VAC Model	12/24 VDC Model	Options Installed
PD6081-6H0	PD6081-7H0	None
PD6081-6H2	PD6081-7H2	2 Relays
PD6081-6H3	PD6081-7H3	4-20 mA Output
PD6081-6H4	PD6081-7H4	4 Relays
PD6081-6H5	PD6081-7H5	2 Relays & 4-20 mA Output
PD6081-6H7	PD6081-7H7	4 Relays & 4-20 mA Output

Note: 24 V Transmitter power supply standard on all models.



- Free Modbus Scanner Software
- Configure a Modbus Scanner
- Conveniently Monitor Critical Information
- Datalog from a PC
- Easy USB Connection

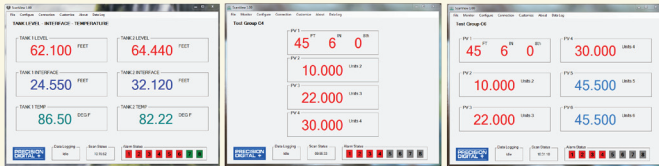

Resident on PD6080/81 Modbus Scanners

Accessories	
Model	Description
PDA1002	DIN Rail Mounting Kit for Two Expansion Modules
PDA1004	4-Relay Expansion Module
PDA1011	Dual 4-20 mA Output Module
PDA1044	4 Digital Inputs & 4 Digital Outputs Module
PDA7485-I	RS-232 to RS-422/485 Isolated Converter
PDA7485-N	RS-232 to RS-422/485 Non-Isolated Converter
PDA8485-I	USB to RS-422/485 Isolated Converter
PDA8485-N	USB to RS-422/485 Non-Isolated Converter
PDX6901	Suppressor (snubber): 0.01 µF/470 Ω, 250 VAC

## PROTEX-MAX EXPLOSION-PROOF

All the proven features of the ProVu brought into your hazardous areas! Go to [www.predig.com/pd8](http://www.predig.com/pd8)



**PD8-6080**  
ProtEX-MAX Explosion-Proof Modbus Scanner

### Disclaimer

The information contained in this document is subject to change without notice. Precision Digital Corporation makes no representations or warranties with respect to the contents hereof, and specifically disclaims any implied warranties of merchantability or fitness for a particular purpose.

©2013-2016 Precision Digital Corporation. All rights reserved.



PD6080/PD6081 come with PDA1485 Serial Adapter and serial cable included.

### Your Local Distributor is:



46, Jalan SS 22/21, Damansara Jaya,  
47400 Petaling Jaya,  
Selangor Darul Ehsan, Malaysia.

Email: [nog@nog.com.my](mailto:nog@nog.com.my)

Web access: <http://www.nog.com.my>

LDS6080\_C 05/16