

# Pipeline Ancillaries

## Liquid Separators AS 2

Combined Valve with Integrated Liquid Separator



### Technical Data

Connection DN	25 + 40
Connection G	1 + 1 1/2
Nominal Pressure PN	16
Operating Pressure	0 - 13 bar
Flow Rate	1900 Nm <sup>3</sup> /h
Collection Efficiency	1200 l/h
Temperature	190 °C
Medium	gases and steam

### Description

Centrifugal separators use the cyclone principle to separate automatically liquids, solids and steam from gas flows while the gas is under operating pressure. The liquid trap built into the separator body operates instantaneously and its operation is not impaired by backpressure or pressure fluctuations. The collected liquid is safely drained by the float control. No additional energy input is required.

Separators type AS2 are of inline design and have their drain outlets at the bottom. Being entirely constructed of corrosion-resistant stainless steel, they can be used universally, i.e. especially for corrosive media.

Top and bottom sections of the valve body are connected by a clamp ring and two bolts. Servicing/maintenance is easy and does not call for special tooling.

### Standard

- » all stainless steel construction (CrNiMo steel)
- » quick-release body clamp ring
- » built-in liquid trap

### Options

- » various seal materials to suit your medium
- » expansion pipe connection in body top section for separating liquids from compressed air or gases
- » other connections on request
- » special designs on request

### Product features in brief

- » inline design with drain outlet at the bottom
- » built in steam trap
- » compact and lightweight thanks to deep-drawn components
- » corrosion-resistant CrNiMo steel
- » various connection options

Please state working pressure range when enquiring or ordering.

Operating instructions, know how and safety instructions must be observed. All the pressure has always been indicated as overpressure. We reserve the right to alter technical specifications without notice.



### Collection Efficiency [l/h] and Pressure Ranges [bar]

Δp bar	G 1, DN 25 pressure range bar			G 1 1/2, DN 40 pressure range bar
	0 - 2	0 - 6	0 - 12	0 - 13
0,1	70	19	6	220
0,2	100	28	9	320
0,5	160	40	12	710
1	230	70	18	980
2	350	110	27	1200
4	-	160	46	1200
6	-	200	50	1200
8	-	-	60	1200
10	-	-	70	1180
12	-	-	75	1030
13	-	-	-	950

# Pipeline Ancillaries

## Liquid Separators AS 2

Combined Valve with Integrated Liquid Separator



### Materials

Nominal Diameter	G 1, DN 25	G 1 1/2, DN 40
Body	CrNiMo-steel	CrNiMo-steel
Body Seal	EPDM optional FEPM	EPDM optional FEPM
Seat, Cone	CrNiMo-steel	CrNiMo-steel
Float	CrNiMo-steel	CrNiMo-steel
Valve Seal	FFKM	CrNiMo-steel

### Dimensions [mm]

size	nominal diameter			
	G 1	G 1 1/2	DN 25	DN 40
A	155	195	195	240
AE	-	238	-	260
B	225	330	225	330
D	140	200	140	200
E	G 1/2A	G 3/4A	G 1/2A	G 3/4A

### Weights [kg]

nominal diameter				
G 1	G 1 1/2	DN 25	DN 40	
2,6	3,5	4,5	6	

Special designs on request.

The pressure has always been indicated as overpressure.

Mankenberg reserves the right to alter or improve the designs or specifications of the products described herein without notice.

### Dimensional Drawing

G 1, DN 25

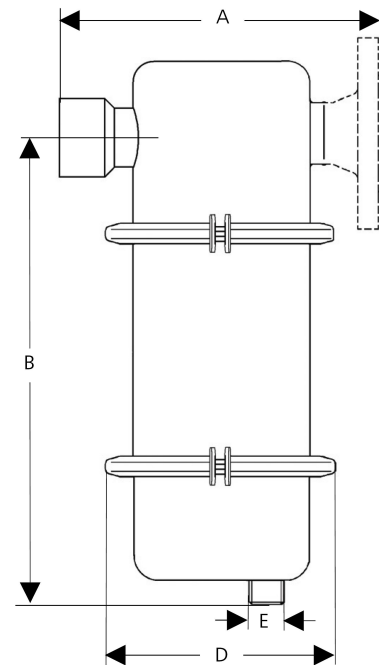

G 1 1/2, DN 40

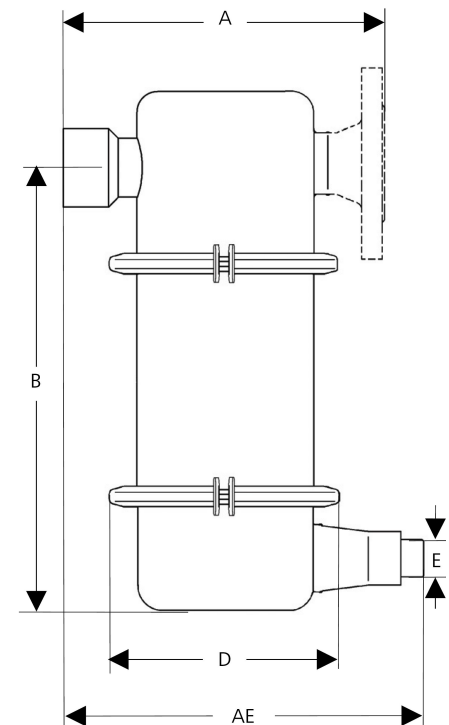

Authorised Distributor:



46, Jalan SS 22/21, Damansara Jaya,  
47400 Petaling Jaya, Selangor Darul Ehsan, Malaysia.

Email: [nog@nog.com.my](mailto:nog@nog.com.my)

Web access: <http://www.nog.com.my>