

BDT18 HP– Industrial high pressure gauge

Product description

Badotherm pressure gauge model BDT18-HP for high pressures above 1600 bar. Badotherm pressure gauge model BDT18-HP is manufactured in full stainless steel and suitable bourdon tube materials. The gauge is not fully in accordance with DIN16001 because of the missing baffle wall and blow out back, however the gauge is following the standard on all other specifications. This pressure gauge is typically used for applications in the hydraulic, water jetting and high pressure environments and machine building and general process industries. The pressure elements are made of special materials to withstand the high pressures. These gauges are designed to withstand the severest of operating conditions of the ambient environment and the process medium.

Design standard

Following DIN 16001 / EN837-1 (where DIN 16001 refers to EN837)

Dial sizes, ranges & accuracy

Possibilities in ranges and accuracies are led by the dial size. Accuracy class is based on dry gauges. Liquid filling can affect the accuracy.

Dial size	Ranges	Accuracy
100mm	>1600 to 0...7000 bar	1.0% <6000 bar
160mm		1.6% 6000, 7000 bar (1% optional)

Mounting variation

Not all gauges are suitable for some mounting variations. For the BDT18 series the mounting variations are below.

- **type A** (10) bottom connection, direct mounting
- **type B** (33) Lower-back connection U-bracket
- **type C** (11) bottom connection, surface mounting (back)
- **type D** (30) lower back connection, direct mounting
- **type E** (32) lower back connection, panel mounting (front)
- **type F** (12) bottom connection, panel mounting (front)

More specifically per gauge size:

Dial size	A	B	C	D	E	F
100mm	•	•	•	•	•	•
160mm	•	• ^{*1}	•	• ^{*1}	• ^{*1}	•

*1) Type B, D and E 160mm only for ≤3000 bar



Process connection

size	Standard thread	optionally
100mm	9/16" UNF Female (According Autoclave F250C)	9/16" 18 UNF LH Male (According Autoclave M562C)
160mm		

Other threads possible on accordance between manufacturer and user.

-> See datasheet "thread information" for specific thread details

Materials of construction

	BDT18 HP
Case	AISI 304 (optionally 316)
Bezel	AISI 304 (optionally 316)
Connection ^{*1}	AISI 316
Sensing element ^{*1}	AISI316 /NiSpan-C 902/ 25CrMo4 ^{*2}
Movement	Stainless steel
Pointer	Aluminium
Dial	Aluminium
Window gasket	NBR
Blow out	NBR
Fill plug	NBR (HNBR for filled gauges)
Mounting flanges	AISI 304
Window	Laminated safety glass

*1) wetted materials

*2) 25CrMo4 is not suitable for water (only for non-corrosive media)

Pressure limitations

The gauges are built to withstand harsh environments however the DIN 16001 limits the use of a pressure gauge according below table.

Dial size	Steady	Fluctuating	Short time
100mm	0.75 x FSV	0.67 x FSV	FSV
160mm			

FSV: full scale value

Temperature limitations

The gauges can withstand ambient and process temperature up to a certain limit. The limitations on temperature are:

	Ambient	Medium
Dry case	-40°C ...+60°C	-40°C...+200°C
Filled case	-20°C ...+60°C	-20°C...+90°C

The variation of indication caused by the effect of temperature shall not exceed: $\pm 0.4\% / 10K FSV$

Window

Standard BDT18 HP gauges have a laminated safety glass.

Pointer

Standard pointer is a fixed black painted aluminum pointer.

As options a slotted and micro adjustable pointer are available

Dial facing

The dial plate is made from aluminum and coated with UV resistant white coating. The black dial markings, scale, numbering, and interval is according the EN 837-1. Options like colored dial, customer logo, or colored segments are possible as well. However, the gauge is following the DIN 16001 it will not be printed on the dial like the BDT-20 HP. ASME dial facing (divisions) available on request (see table 3)

Limit stop

The BDT18 HP has a limit stop on the movement to prevent, in case of overpressure, the pointer reentering the scale (graduations) thus preventing the operator reading a low pressure when in fact the pressure is dangerously high. This internal limit stop normally engages at approx. 130% of full scale value. The gauges have a free zero.

Degree of protection

The BDT18 has a standard degree of protection of IP65. The values are determined according the IEC/EN 60529. Class IP66 and IP67 are available as option.

Case filling

The gauges can be filled with different kind of fill fluids. The fill fluids available are:

- BPF01 – Glycerine 86%
- BPF02 – Silicon
- BPF06 – Glycerine 99.5%

Restrictor Screw

All gauges can be executed with a restrictor of 0.8 or 0.3 orifice in AISI316. Optional the restrictor can be secured in the connection so the restrictor cannot come out with vibration and damage your installation.

Certification & Declaration

Calibration

Gauges are full range calibrated as a factory standard. Optionally you can select a 5 points calibration certificate, and a 10 points calibration certificate.

[Pressure Equipment Directive - 2014_68_EU](#)

PED approval is given according article 3.3 and is valid for ranges >200 bar. All gauges will be marked accordingly. A declaration of conformity can be supplied.

[ATEX 114 - 2014/68/EU](#)

ATEX restrictions are explained in the IOM and in the ATEX background datasheet.

[EN 10204 material certificate](#)

A material 3.1 certificate on the wetted parts can be supplied.

Dimensions table

Type A (10)

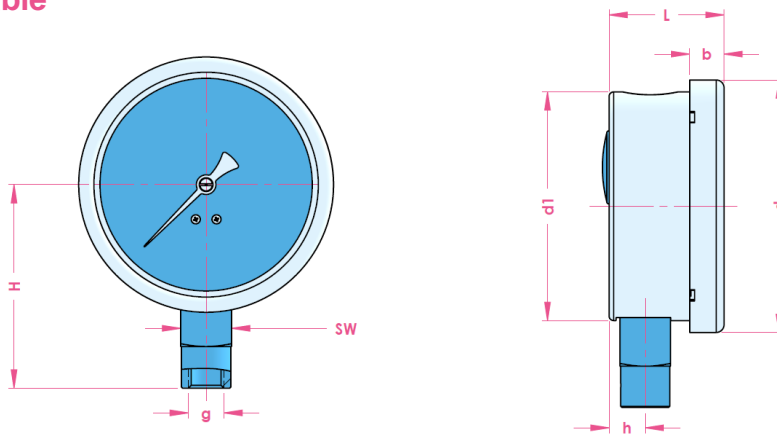

Dial size	d	d1	b	L	h	g	SW	H	weight
100/100R	110.0	100.0	15.0	49.0	15.8	9/16" UNF	22	85.0	0.5 kg
160/160R	160.0	149.0	16.0	50.0	16.0			117.0	0.8 kg

Type B (33)

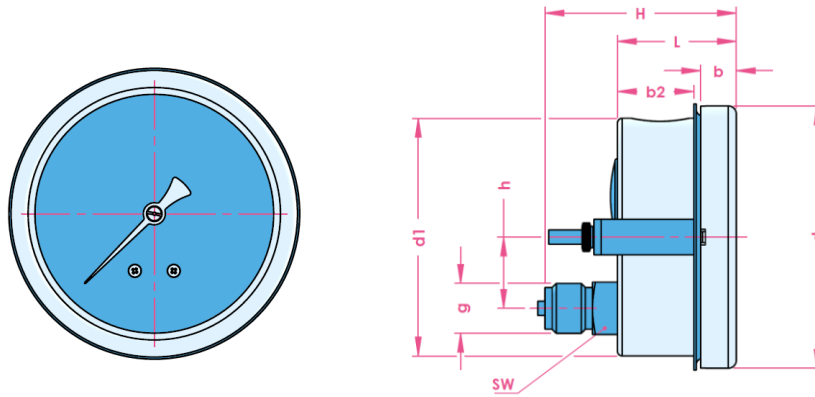

Size	d	d1	b	b2	L	h	g	SW	H	weight
100	110.0	100.0	15.0	30.0	50.0	30.0	G 1/2 A	22	80.5	0.6 kg
160	160.0	150.0	16.0	29.5	52.0	48.5			82.0	0.8 kg

Type C (11)

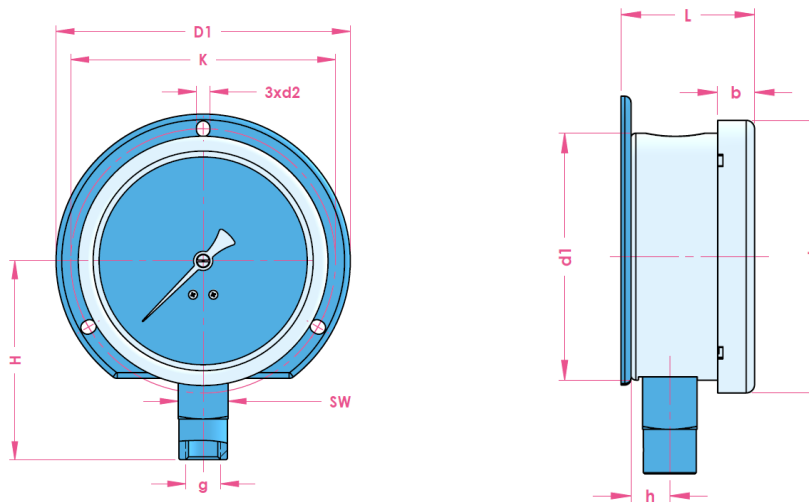

size	d	d1	b	L	h	K	D1	d2	g	SW	H	weight
100	110.0	100.0	15.0	49.0	15.8	118.0	130.0	6.0	9/16" UNF	22	88.0	0.5 kg
160	160.0	150.0	16.0	50.0	16.0	178.0	196.0				120.0	0.8 kg

Type D (30)

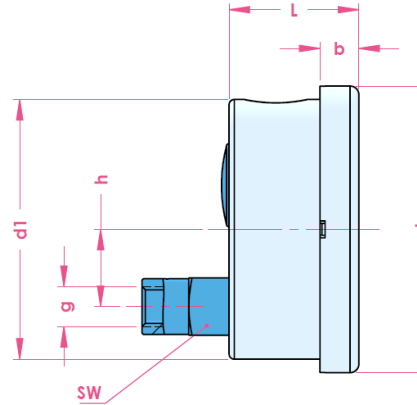
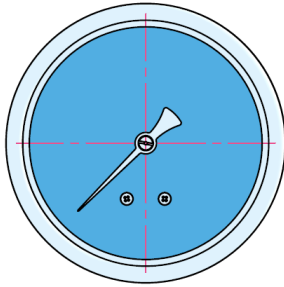

Dial size	d	d1	b	L	h	g	SW	H	weight
100	110.0	100.0	15.0	49.0	30.0	9/16" UNF	22	83.0	0.5 kg
160	160.0	149.0	16.0	50.0	48.5			125.5	0.8

Type E (32)

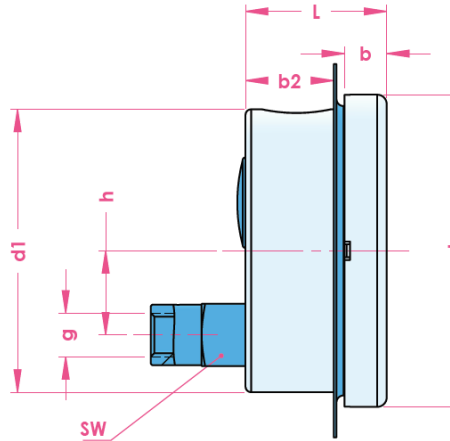
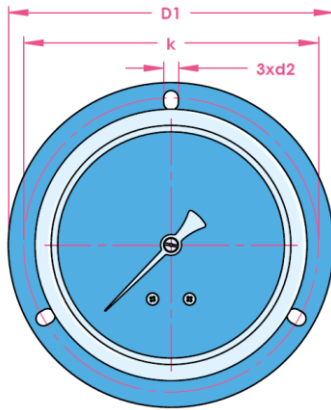

Dial size	d	d1	b	b2	L	h	K	D1	g	SW	H	weight	
100	110.0	100.0	15.0	30.0	49.0	30.0	117.6	132.0	6.0	9/16" UNF	22	80.5	0.5 kg
160	160.0	149.0	16.0	29.5	50.0	48.5	178.0	190.0				82.0	0.8 kg

Type F (12)

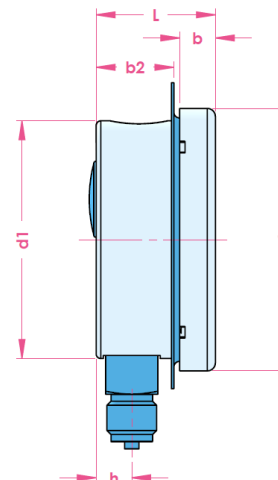
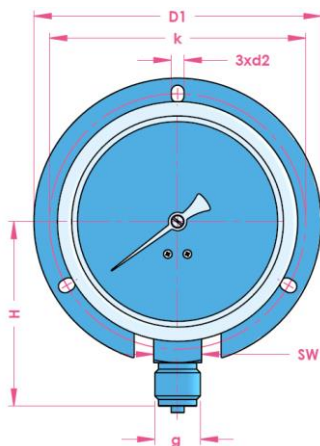

Dial size	d	d1	b	L	h	K	D1	g	SW	H	weight
100/100R	110.0	100.0	15.0	50.0	30.0	117.6	132.0	G ½ A	22	85.0	0.5 kg
150/150R	160.0	150.0	16.0	52.0	48.5	168.0	190.0			117.0	0.8 kg
160/160R						178.0				0.8 kg	

Product code 100mm

Code	
	BDT18 HP 100 A U20M S363 S304 F 0 L B83 10
TYPE	
100 mm ◀	100
MOUNTING	
Bottom connection - direct mounting (10) ◀	A
Lower-back connection U-bracket (33)	B
Bottom connection - surface mounting (11)	C
Lower back connection. - direct mounting (30)	D
Lower back connection.- panel mount (32)	E
Bottom connection, panel mounting (front) (12)	F
CONNECTION	
9/16" UNF female (F250C) ◀	U20M
9/16" - 18 UNF LH male (M562C)	U50M
M16 x 1.5 female HP connection	M16F
TUBE & SOCKET MATERIAL	
AISI316 / AISI316L (<3000 bar) ◀	S363
NiSpan C 902 / AISI316L ◀	C902
25CrMo4 / AISI316L*1	C52M
CASE/BEZEL MATERIAL	
AISI 304 ◀	S304
AISI 316	S300
POINTER	
Fixed pointer ◀	F
Adjustable slotted pointer	A
Micro adjustable pointer	M
LIQUID FILLING	
Dry ◀	0
BPF 01 - Glycerine filled 1,23 (86%)	1
BPF 06 - Glycerine filled 1,26 (99,5%)	6
BPF 02 - Silicone filled	2
WINDOW	
Laminated safety glass (S1) ◀	L
RANGE	
See page table 1 and table 2
ACCURACY	
1.0	10
1.6 ◀	16

◀: is the sign for the standard pressure gauge

*1: option only for 3000 bar gauge / 25CrMo4 is not suitable for water (only for non-corrosive media)

Product code 160mm

Code	
	BDT18 HP 160 A U20M S363 S304 F 0 L B83 10
TYPE	
160 mm ◀	160
MOUNTING	
Bottom connection - direct mounting (10) ◀	A
Lower-back connection U-bracket (33)	B
Bottom connection - surface mounting (11)	C
Lower back connection. - direct mounting (30) *2	D
Lower back connection.- panel mount (32) *2	E
Bottom connection, panel mounting (front) (12)	F
CONNECTION	
9/16" UNF female (F250C) ◀	U20M
9/16" - 18 UNF LH male (M562C)	U50M
M16 x 1.5 female HP connection	M16F
TUBE & SOCKET MATERIAL	
AISI316 / AISI316L(<3000 bar) ◀	S363
NiSpan C 902 / AISI316L ◀	C902
25CrMo4 / AISI316L*1	C52M
CASE/BEZEL MATERIAL	
AISI 304 ◀	S304
AISI 316	S300
POINTER	
Fixed pointer ◀	F
Adjustable slotted pointer	A
Micro adjustable pointer	M
LIQUID FILLING	
Dry ◀	0
BPF 01 - Glycerine filled 1,23 (86%)	1
BPF 06 - Glycerine filled 1,26 (99,5%)	6
BPF 02 - Silicone filled	2
WINDOW	
Laminated safety glass (S1) ◀	L
RANGE	
See page table 1 and table 2
ACCURACY	
1.0	10
1.6 ◀	16

◀: is the sign for the standard pressure gauge

*1: option only for 3000 bar gauge / 25CrMo4 is not suitable for water (only for non-corrosive media)

*2: Type D and E 160mm only for ≤3000 bar

Table 1: Pressure Range code

bar		psi		MPa		kgf/cm2	
Code	Range	Code	Range	Code	Range	Code	Range
B77	0...1800	P78	0...30.000	N77	0...180	K77	0...1800
B78	0...2000	P80	0...40.000	N78	0...200	K78	0...2000
B79	0...2500	P83	0...60.000	N79	0...250	K79	0...2500
B80	0...2800	P85	0...80.000	N80	0...280	K80	0...2800
B81	0...3000	P87	0...100.000	N81	0...300	K81	0...3000
B82	0...3500			N82	0...350	K82	0...3500
B83	0...4000			N83	0...400	K83	0...4000
B87	0...7000			N87	0...700	K87	0...7000

Table 2: Secondary scale

Dual scale option	code
PSI red	#PR
PSI black	#PB
PSI blue	#PBL
bar red	#BR
bar black	#BB
bar blue	#BBL
kPa blue (x100)	#LBLX

Add the code behind the pressure code
(eg B45#PR for 0...10 bar/psi with red scale)

Table 3: General option code

Option (start options with X_)	code
IP 66 class	_IP66
IP 67 Class	_IP67
Index pointer	_IP
Restrictor screw 0.8mm	_RS8
Restrictor screw 0.3mm	_RS3
Calibrated at 0°	C0
Calibrated at 180°	_C180
ATEX II2GDc-IM2c	_ATEX
3.1 material certificate	_IC31
Calibration certificate 5 points	_CC5
Calibration certificate 10 points	_CC10
ASME division on scale range	_ASC

Authorised Distributor:



46, Jalan SS 22/21, Damansara Jaya,
47400 Petaling Jaya,
Selangor Darul Ehsan, Malaysia.

Email: nog@nog.com.my

Website: www.nog.com.my

Change log

Date	Change
6-5-2020	Added ASME scale division as option in table 3
	Added kPa blue (x100) option as secondary scale
	Added type B and F as mounting option.

Holland – Romania – India – Thailand – Dubai – USA

To our knowledge, the information contained herein is accurate as of the date of this document. However neither Badotherm, nor its affiliates makes any warranty, express or limited, or accepts any liability in connection with this information or its use. This information is for technical skilled persons at their own discretion and risk and does not relate to the use of this product in combination with any other product. The user alone finally determines suitability of any information or material in contemplated use, the manner of use and whether any patents are infringed. This information gives typical properties only. Badotherm reserves the right to make changes to the specifications any materials without prior notice. The latest version of the datasheet can be found on www.badotherm.com.

© 2015 Badotherm, all rights reserved. Trademarks and/or other products referenced herein are either trademarks or registered trademarks of Badotherm.